

MULTIFILL SERIES PHARMA

HIGH SPEED ROTARY FILLING & CLOSING MACHINES



MULTIFILL F500 SERIES

Multifill F500 Series of rotary filling and closing machines is the result of over 40 years' activity in the field of liquid filling. Modular and flexible this Series of machines offers the pharmaceutical industry the right technological filling solutions.

With a high degree of flexibility and modularity this machine Series allows compact and effective combinations to satisfy even the most stringent filling requirements.

ROBUST, EFFICIENT AND SAFE, THESE MACHINES ARE CAPABLE OF WORKING UNDER EXTREME PRODUCTION LOADS.

(3 daily shifts) and can count on a very compact overall layout; the high reliability is proven by hundreds of machines supplied and working successfully worldwide.

In the monobloc version the F500 Series of machines is very compact and ergonomic and couples the filling operation with one or two closing stations. The closing turrets can be equipped with various types of closing heads for all types of closures, such as screw caps, push-on caps, aluminium ROPP caps, droppers, reducers, pumps, dip tubes, etc. typical of pharmaceutical applications.

The compact displacement of the operative groups allows the possibility to handle unstable containers into pucks, simplifying in this way even the more difficult packaging operations.

All machines are standard supplied with safety soundproof guards, Siemens S7 PLC and are built in AISI 304 and AISI 316 L st.st. The wide range of machine models available allows the F500 Series of machines to be part of complete packaging lines.



HIGH-SPEED ROTARY FILLING & CLOSING MACHINES



THANKS TO THE HIGH LEVEL OF INTEGRATION AND TO THE PROVEN RELIABILITY OF THE INDIVIDUAL MACHINE, THE IMA LIFE LINES PROVIDE HIGH OUTPUT FOR THE ENTIRE PRODUCTION PROCESS.

THE F500 SERIES OF MACHINES

- MULTIFILL F540
STAND-ALONE FILLER
- MULTIFILL F550/G550
STAND-ALONE CLOSING MACHINE
- MULTIFILL F570
FILLING & CLOSING MACHINE
- MULTIFILL F572
CLOSING MACHINE WITH 2 OPERATIONS
- MULTIFILL F573
FILLING & CLOSING MACHINE
WITH 2 OPERATIONS IN MONOBLOC

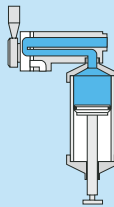

CERAMIC FRONT VALVE & STAINLESS STEEL SYRINGE UP TO 300 ML

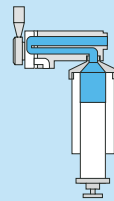

CERAMIC FRONT VALVE & CERAMIC SYRINGE UP TO 200 ML

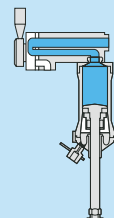

CERAMIC FRONT VALVE & STAINLESS STEEL SYRINGE UP TO 250 ML FOR CIP/SIP

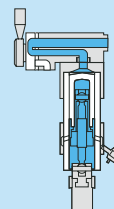

CERAMIC FRONT VALVE & CERAMIC SYRINGE UP TO 140 ML FOR CIP/SIP

MULTIFILL F500 SERIES

F500 SERIES OF MACHINES CAN PERFORM: FILLING + 1 OR 2 CLOSURES IN THE SAME MONOBLOC CLOSING ONLY, WITH 1 OR 2 CLOSING TYPE OPERATIONS.

Ideal for a variety of products, such as syrups, solutions, suspensions, eye and ear-drops, sugar or viscous intranasal products, the machines of the F500 Series can handle from 2 to 300 ml filling volume with an output of up to 400 bpm, featuring volumetric dosing pumps (stainless steel or ceramic) with separated front valve. Possibility of nozzles with pneumatic actuator.



HIGH-SPEED ROTARY FILLING & CLOSING MACHINES



MANY ADDITIONAL UNITS ARE AVAILABLE ON REQUEST

- AUTOMATIC FEEDERS FOR UNSTABLE CONTAINERS
- CIP/SIP SYSTEM OF THE DOSING UNITS
- “NO BOTTLE - NO FILL” DEVICE
- SERVOMOTORS FOR DOSING ADJUSTMENT
- EX-PROOF EXECUTION TO HANDLE ALCOHOL-BASED PRODUCTS
- INCOMPLETE VIAL REJECTION SYSTEM

MULTIFILL F540 STAND-ALONE FILLER

Rotary machine with 12 dosing units and capacity from 2 to 300 ml. The filling unit can be separated from the feeding one by loosening a single screw, for quick and easy cleaning and sanitization operations.

F540 is ideal for applications requiring a stand-alone dosing machine that can be combined with different closing machines for any kind of pharmaceutical closures.

MULTIFILL F570 FILLING & CLOSING MACHINE

Rotary machine with 12 filling units and 8 closing heads. Extremely compact, F570 features an effective system to center bottles during dosing that allows the machine to handle unstable containers, too. Thanks to a bottom-up filling system, the machine is ideal for very foamy products. The closing turret can be fit with various types of heads for all types of closures used for pharmaceutical applications.

MULTIFILL F573 FILLING & CLOSING MACHINE WITH 2 OPERATIONS IN MONOBLOC

Rotary machine with 12 dosing units with 2 closing groups, each accommodating 8 closing heads, in order to apply two different or complementary closures at the same time.

This version is particularly compact and ideal for pharmaceutical applications such as drops or syrups, with the possibility of easy integration in high-speed lines.

MULTIFILL F500 SERIES

STAND ALONE CAPPERS LIKE F550/G550 AND F572 CAN APPLY VERY DIFFICULT CLOSURES OR THOSE REQUIRING SPECIAL POSITIONING OR CENTRING IN ADDITION TO TRADITIONAL CLOSURES, TYPICALLY USED IN THE PHARMACEUTICAL SECTOR.



MULTIFILL F550/G550 & MULTIFILL F572 SHARE THE SAME FEEDING AND CLOSING UNITS AND THUS HAVE THE SAME GREAT FLEXIBILITY.

ALU-CAPPING APPLIED FORCE CHECK AND CAPPING TORQUE CONTROL ARE POSSIBLE FEATURES ON BOTH F550/G550 AND F572 MACHINES.

These machines feature closing operations by means of screwing, pressure system, crimping of aluminium seal and can vary closure type with quick size change-over.

They find application in all production sites which require filling on a segregated area.



HIGH-SPEED ROTARY CLOSING MACHINES



A QUICK SIZE CHANGE-OVER
IS A PRIMARY FEATURE.

MULTIFILL F550/G550 STAND-ALONE CLOSING MACHINE

Rotary closing machine with one operation that closes by screwing or pressure of plastic push-on caps or by crimping of aluminium seals. It can vary closure type with quick-size change-over.

G550 is a special version for application of standard aluminium or Flip-off caps, with production speed of up to 400 bpm. It can be equipped with a device to check the vertical pressure exerted on the cap during crimping and with a laminar flow hood.

MULTIFILL F572 CLOSING MACHINE WITH 2 OPERATIONS

Continuous rotary capping machine with two closing stations, each with 8 heads, for the application of two different closures.

Thanks to the wide angle used to perform the capping operation F572 can apply very difficult closures or those requiring special positioning, in addition to the traditional ones used in the pharmaceutical sector.

Ideal to apply different closures without having to perform size change-over.



MULTIFILL F800 SERIES

To confirm the continuous trend towards innovation, **by further updating and upgrading its filling technology** IMA Life offers today the pharmaceutical industry state-of-the-art machines.

Combining essential features and the simplicity of proven dosing systems with widely appreciated high standards of quality and reliability F800 Series of high speed volumetric fillers is the **ultimate innovation** in the IMA Life filling range. Particularly versatile F800 Series has been conceived to reach an output speed of up to 450 bpm with up to 24 filling heads and 10 closing heads with a max. dosing volume of 1000 ml.

Thanks to its constructive modular design, the machine can handle all types of plastic and glass bottles, in any shape and with all the closures typical of the pharmaceutical products.

IMA Life, in cooperation with some of the major pharmaceutical multinationals, has developed an exclusively new automatic stand-alone CIP/SIP system for its F800 Series of Rotary Fillers, which remarkably reduces the manual intervention of the operator with a subsequent saving on time and money.

All the manual operations between the CIP and the SIP phase have been eliminated and are carried out automatically. The flexible pipes for the washing media and for the steam are now easily connected one to the other and to the fluid discharge manifold, by means of quick-connects.

This system avoids any spillages, leaks or sprays of liquids during the entire cleaning process.

A special system consisting of a double chamber rigid pipe, allows a thorough cleaning of the outer walls of the filling nozzles by means of a forced detergent flow and extraction (IMA Life Patent Pending).

The system is fully validated.

The closing turret can be equipped with brushless motors on each individual capping head to allow orientation of push on caps and torque control during tightening operation with monitoring of the force applied to each single bottle. Automatic adjustment of dosing and closing turret height by means of servomotor.



HIGH-SPEED ROTARY FILLING & CLOSING MACHINES



THE F800 SERIES OF MACHINES

- MULTIFILL F840
STAND-ALONE FILLER
- MULTIFILL F850
STAND-ALONE CLOSING MACHINE
- MULTIFILL F870
FILLING & CLOSING MACHINE
- MULTIFILL F872
CLOSING MACHINE WITH 2 OPERATIONS
- MULTIFILL F873
FILLING & CLOSING MACHINE WITH 2
OPERATIONS IN MONOBLOC

IDEAL FOR BIG BATCH PRODUCTION, F800 SERIES OF MACHINES CAN BE EQUIPPED WITH THE LATEST GENERATION OF COMPLETELY AUTOMATED CIP-SIP SYSTEMS.



MULTIFILL SERIES TECHNICAL DATA

F540

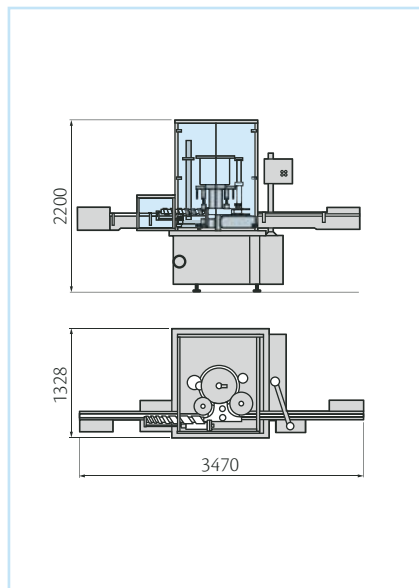

F570

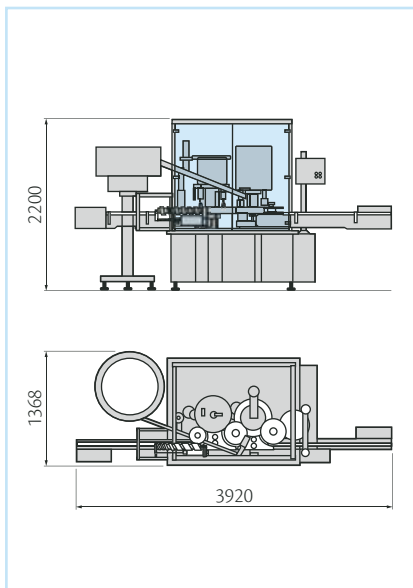

F573

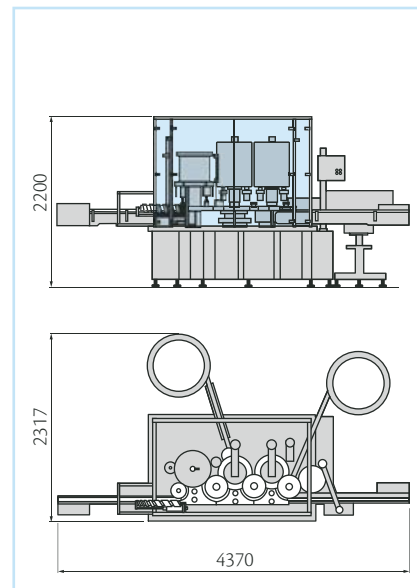

MODEL	F550/G550		F572		F540		F570		F573	
	Min.	Max.	Min.	Max.	Min.	Max.	Min.	Max.	Min.	Max.
Bottle diameter (mm)	16	80	16	80	16	80	16	80	16	80
Bottle height (mm)	40	270	40	270	40	185	40	185	40	165
Max. closure diameter (mm)	-	40	-	40	-	-	-	40	-	40
Filling heads	-		-		(6) 12		(6) 12		(6) 12	
Closing heads	(4) 8		(4+4) 8+8		-		(4) 8		(4+4) 8+8	
Out-put (bottles/h)	Up to 24000		Up to 24000		Up to 24000		Up to 24000		Up to 24000	
Installed power	4,5 kW		5,5 kW		3 kW		5 kW		6 kW	
Voltage	400 V - 50 Hz		400 V - 50 Hz		400 V - 50 Hz		400 V - 50 Hz		400 V - 50 Hz	
Weight	1800 Kg		2700 Kg		1600 Kg		2500 Kg		2700 Kg	

F550/G550

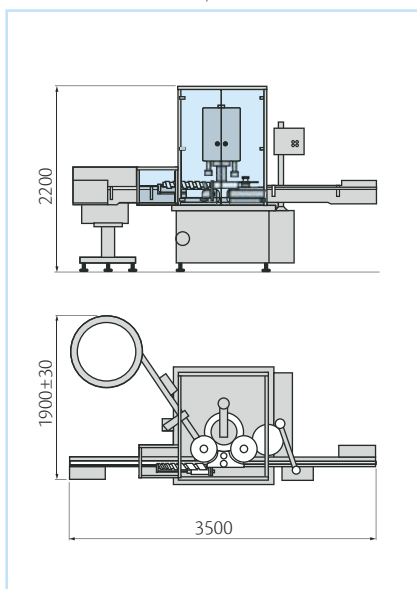

F572

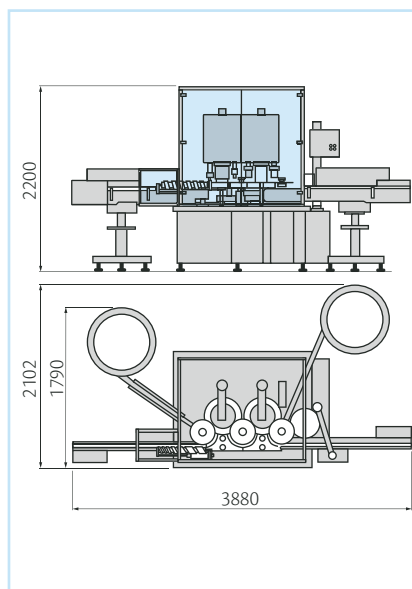

F840

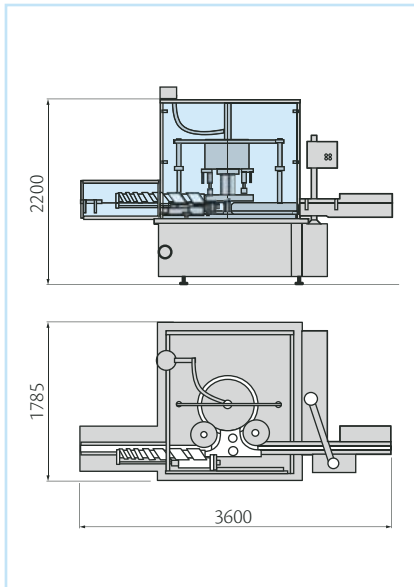

F850

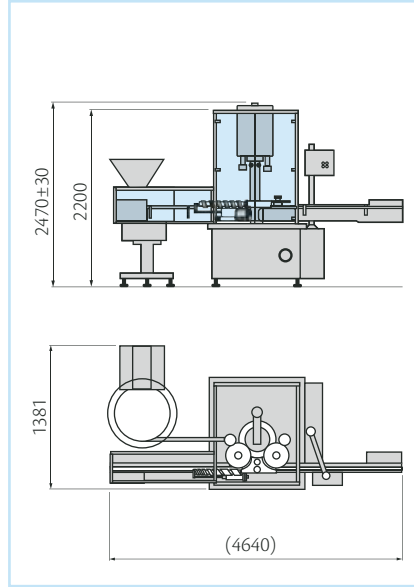

F872

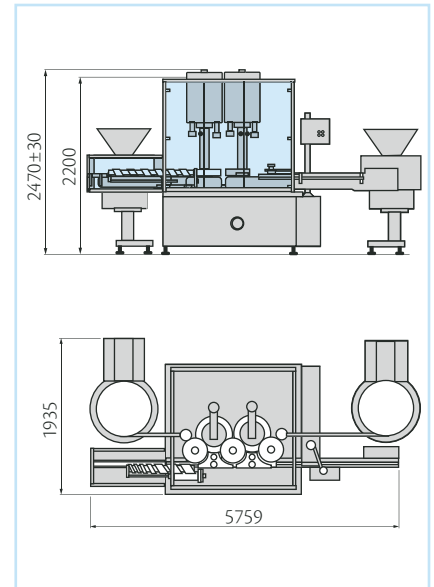

MODEL	F850		F872		F840		F870		F873	
	Min.	Max.	Min.	Max.	Min.	Max.	Min.	Max.	Min.	Max.
Bottle diameter (mm)	16	80/95*	16	80/95*	16	80/95*	16	80/95*	16	80/95*
Bottle height (mm)	40	200/230*	40	200/230*	40	200	40	200	40	200
Max. closure diameter (mm)	60		60		-		60		60	
Filling heads	-		-		12/18/24		12/18/24		12/18/24	
Closing heads	6/8/10		6+6/8+8/10+10		-		6/8/10		6/8/10	
Out-put (bottles/h)	Up to 27000		Up to 27000		Up to 27000		Up to 27000		Up to 27000	
Installed power	5 kW		6 kW		5 kW		7 kW		8 kW	
Voltage	400 V - 50 Hz		400 V - 50 Hz		400 V - 50 Hz		400 V - 50 Hz		400 V - 50 Hz	

(*) Depending on number of closing heads

F870

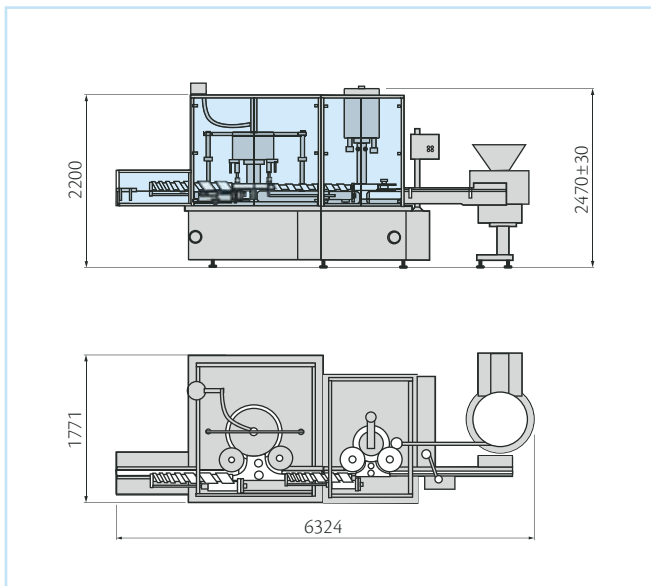

F873

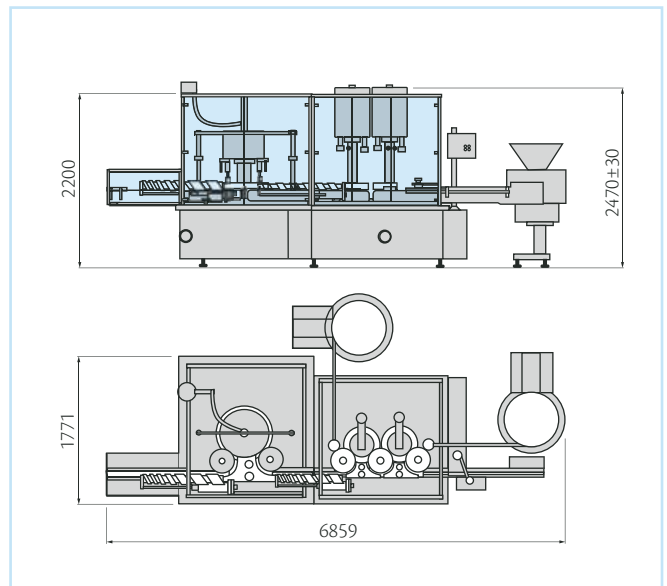

www.ima-pharma.com

IMA S.p.A.

IMA LIFE division

Via Emilia 428-442 - 40064 Ozzano dell'Emilia (Bologna) - Italy

Tel. +39 051 6514111 - Fax +39 051 6514666

mktg.life@ima.it - www.ima.it



Certificate
N. IT00/0415