

# IMILL

CONE MILL

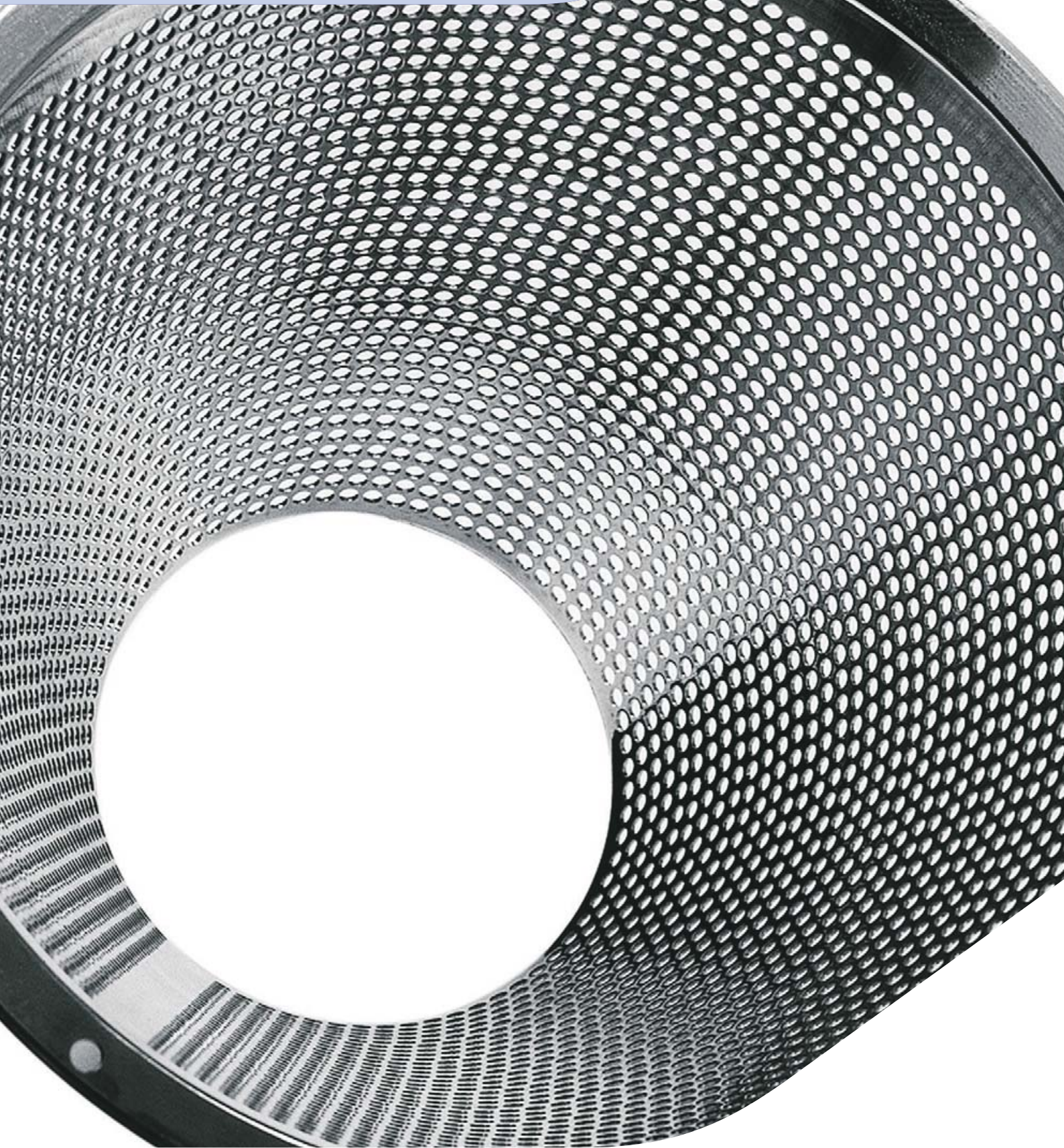

# IMILL CONE MILL

The Imill series of cone mills are suitable for wet or dry products, processed within the pharmaceutical, food, nutraceutical and cosmetic industry.

Typical applications for the Imill are:

- Size reduction and delumping of raw materials prior to powder mixing or granulation.
- Delumping of wet granules to facilitate the drying step.
- Uniform dry granule particle size to facilitate compression or capsule filling steps.



THE IMILL SERIES OF CONE MILLS CAN OPERATE EITHER AS A FREE STANDING EQUIPMENT OR ALSO INTEGRATED IN OTHER EQUIPMENT CONTROL SYSTEM



Imill integrated with Rotomix high shear mixer granulator

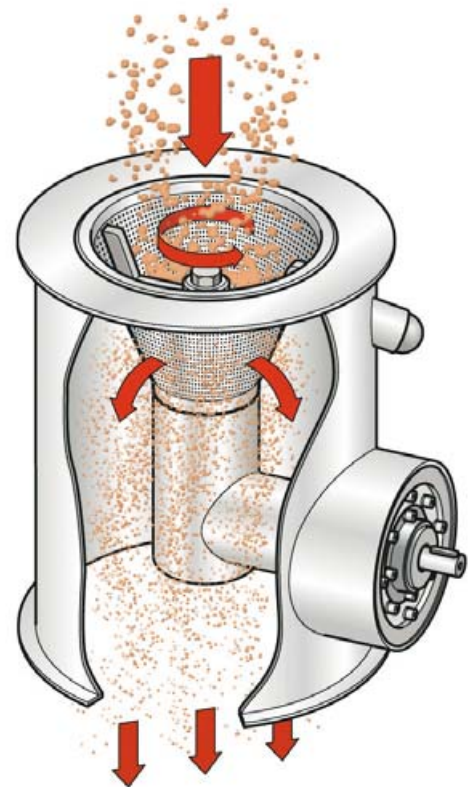

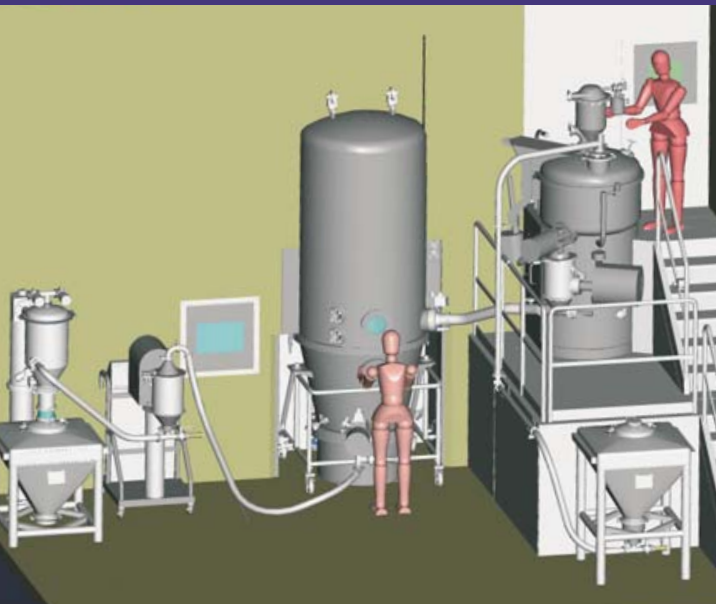

The required particle reduction size can be achieved by changing the Imill screen and regulating the speed of the impeller. Conical screens are available in various shapes and mesh sizes to handle size reduction of wet, dry, soft and hard products.

## WORKING PRINCIPLES

The solid product is fed into the Imill by gravity or vacuum, the rotation of the impeller forces the product tangentially through the conical screen without generating any friction.

The product, driven by centrifugal acceleration, passes through the holes of the screen with continuous, fast flow rate, low fine generation, no overheating and minimum noise.

Afterwards the product is discharged by gravity and can be collected into bags, drums or conveyed directly to the next process stage.

## AVAILABLE OPTIONS:

- ATEX VERSION
- TEMPERATURE PROBE
- NOZZLES FOR WASH IN PLACE
- TROLLEY WITH HEIGHT REGULATION



Imill - free standing equipment



# IMILL TECHNICAL DATA

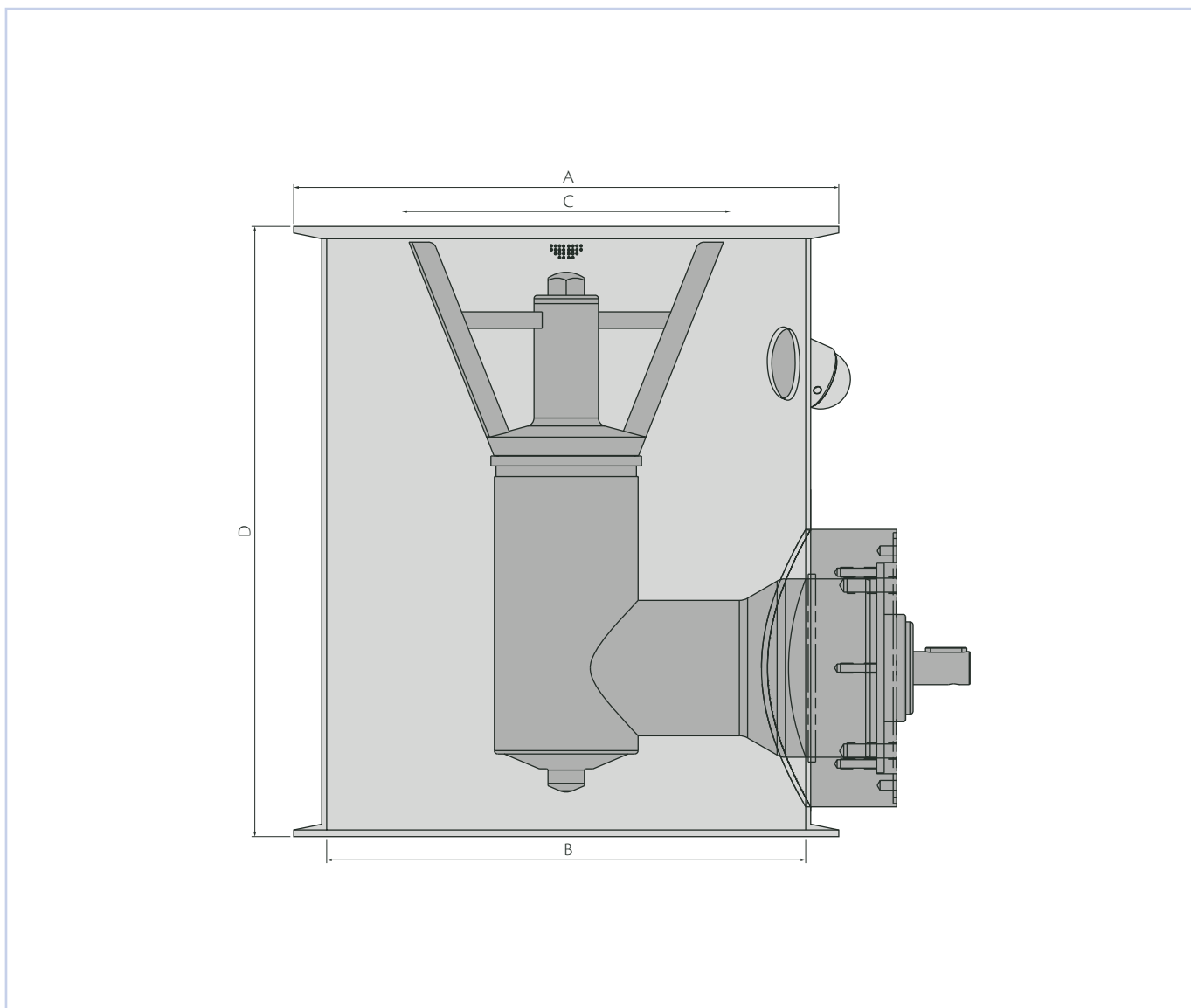

MODEL	IMILL 5	IMILL 8	IMILL 12
Capacity (kg/h)*	N. A.	1,500	4,000
Motor (kW)	1.5	4.0	5.5
Speed range (rpm)	500-4,000	300-1,600	
A (mm)	180	330	500
B (mm)	132.5	290	414
C (mm)	125.8	199.7	301.5
D (mm)	222	369.5	420

\*Capacity can vary depending on product characteristics, particle size distribution, screen size and installation context.

IMA S.p.A.

## IMA ACTIVE division

Via l° Maggio 14 - 40064 Ozzano Emilia (Bologna) - Italy

Tel. +39 051 6514111 - Fax +39 051 6514287

mktg.soliddose@ima.it - www.ima.it - [www.ima-pharma.com](http://www.ima-pharma.com)

