

[www.silverson.com](http://www.silverson.com)

# *high shear mixers*

*the first name in high shear mixers*



*better mixers, better results*



## The Silverson way

For over 60 years Silverson has specialised in the manufacture of quality high shear mixers for processing and manufacturing industries worldwide.

With customers in over 150 countries, and serving industries as diverse as food, pharmaceuticals, cosmetics, lubeoils and petrochemicals, Silverson has become the world leader in the field of high shear mixing. Time after time, companies specify Silverson mixers as the “standard” equipment for their manufacturing process.

The key to this success is based on the professionalism and commitment Silverson shows to each of its customer's needs. Whether supplying machines from its standard range of mixers or designing equipment specifically to meet an individual customer's requirements, quality is guaranteed.

With a customer base that includes many of the world's largest companies, Silverson is constantly at the forefront of new technologies. Developing and applying new high shear mixing techniques to meet these needs, Silverson has the experience, knowledge and commitment to both quality and service to solve today's mixing needs and those of the future.

A truly international company, Silverson is represented by a network of associated companies, distributors and agents in over 50 countries, serving North America, Europe, Asia, Australasia, South America and Africa.





# The Silverson advantage

## **Speed**

The exceptionally rapid Silverson mixing action substantially reduces process times compared with conventional agitators and mixers, and can reduce mixing times by up to 90%.

## **Versatility**

The advantage of the Silverson approach to mixing is that any one machine can perform the duties that in the past may have required several different pieces of process equipment. This unrivalled versatility allows any machine to perform the widest range of mixing applications:

## **Blending**

A homogeneous product is rapidly produced when blending liquids of similar or greatly varying viscosities, eliminating problems such as stratification.

## **Emulsifying and homogenising**

Emulsions (typically in the range of 0.5 to 5 microns) can be easily achieved.

## **Disintegration**

All Silverson rotor/stator mixers can disintegrate matter of animal, vegetable, mineral or synthetic origin in a single operation.

## **Particle size reduction**

Uniformly mill both solid and semi-solid materials into either solution or fine suspension.

## **Gelling and solubilising**

The high shear action of the Silverson rotor/stator can rapidly disperse gums, alginates, C.M.C., carbopols, etc., resulting in an agglomerate-free solution within minutes.

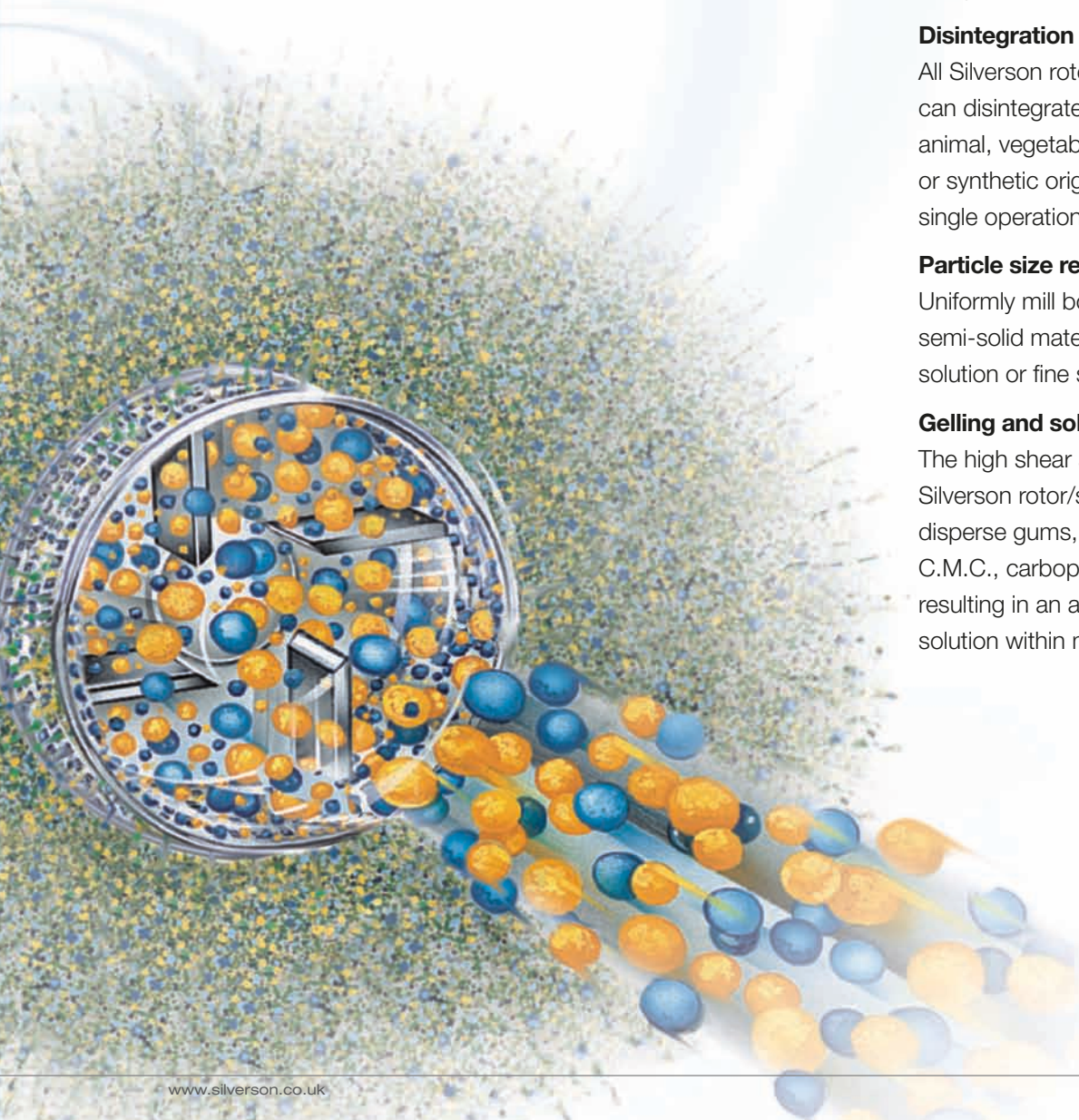

## How the Silverson works

The advantages of Silverson's high shear rotor/stator mixer over simple conventional stirrers or agitators stem from the multistage mixing/shearing action as materials are drawn through the specially designed Silverson workhead - the heart of every machine.

### Stage 1

The high-speed rotation of the rotor blades within the precision machined mixing workhead exerts a powerful suction, drawing liquid and solid materials upwards from the bottom of the vessel and into the centre of the workhead.

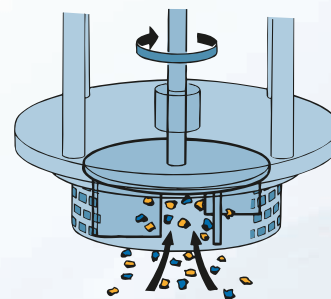

### Stage 2

Centrifugal force then drives materials towards the periphery of the workhead where they are subjected to a milling action in the precision machined clearance between the ends of the rotor blades and the inner wall of the stator.

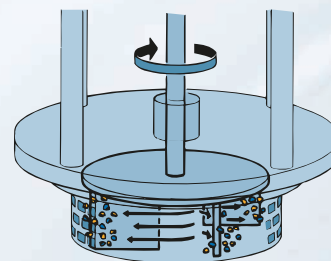

### Stage 3

This is followed by intense hydraulic shear as the materials are forced, at high velocity, out through the perforations in the stator and circulated into the main body of the mix.

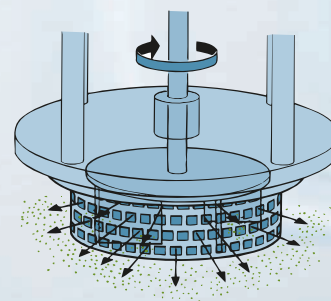

### Stage 4

The materials expelled from the head are projected radially at high speed towards the sides of the mixing vessel. At the same time, fresh material is continually drawn into the workhead maintaining the mixing cycle. The effect of the horizontal (radial) expulsion and suction into the head is to set up a circulation pattern that minimises aeration caused by the disturbance of the liquid's surface.

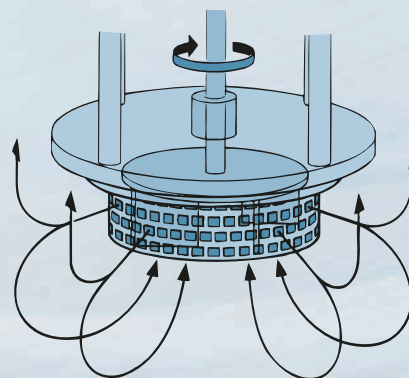

## Interchangeable heads and screens

A comprehensive range of workheads and screens is available for all Silverson rotor/stator mixers. These easily interchangeable workheads offer great versatility by allowing any machine to be adapted to perform a wide range of mixing operations including emulsifying, homogenising, disintegrating, dissolving, dispersing, blending, particle size reduction and de-agglomerating. Changing from one head or screen to another is quick and simple.

### **General purpose disintegrating head**

This is the most versatile of all the heads, giving an exceptionally vigorous mixing action. Ideal for general mixing applications, its uses also include the disintegration of solids and the preparation of gels and thickeners, suspensions, solutions and slurries.



### **Slotted disintegrating head**

For the disintegration of fibrous materials such as animal and vegetable tissue, as well as the disintegration and solubilisation of "elastic" materials such as rubbers and polymers.



### **Square hole high shear screen™**

Provides exceptionally high shear rates ideal for the rapid size reduction of soluble and insoluble granular solids. It is also suitable for the preparation of emulsions and fine colloidal suspensions.



### **Standard emulsor head and emulsor screen**

Suitable for liquid/liquid preparations and especially useful for all emulsions. Emulsor screens are available in fine, medium or coarse perforations.





## Silverson service

### **Experience and know how**

Silverson has been the leader in High Shear Mixing technology for over 60 years and has built up a detailed knowledge of mixing process requirements. This accumulated knowledge enables our technical staff and sales representatives to clearly identify a client's needs and recommend the type of mixer most suited to provide an efficient and economical solution.

### **Extensive test facilities**

Available for the use of all clients, Silverson operates dedicated test facilities equipped with a wide range of laboratory and production scale machines where customers may test new products and discuss their applications with our technical staff. If preferred, Silverson mixers can be provided for on-site trials to allow evaluation under actual production conditions.

### **Customisation**

Increasingly today's process manufacturers require equipment to be designed to meet their own particular needs. Silverson has a positive approach and flexibility which allows mixers to be custom designed and built to suit individual user's specific requirements.

### **Worldwide support**

A truly international company, Silverson is represented by a network of associated companies, distributors and agents in over 50 countries, serving Europe, North America, Asia, Australasia, South America and Africa.

### **Installation**

Silverson offers expert advice and, if required, can assist with and supervise installation and start up.

### **After-sales service**

With over 60 years of experience Silverson realises the importance their customers place on reliable and rapid back-up service. Our large stock of manufactured parts enables us to despatch most standard spares the same day they are ordered.



## Some of Silverson's clients

Silverson is pleased to be able to service the exacting needs of some of the finest companies in the world.



These trademarks & company logos are included with the kind permission of the owners.



*better mixers, better results*

## Laboratory scale mixers

Silverson Laboratory mixers are suitable for the widest range of applications - mixing, emulsifying, homogenising, disintegrating, dissolving - with an efficiency and flexibility unmatched by other machines. With a capacity from 1ml up to 12 litres and the ability to mix in-line with flow rates up to 20 litres/minute, they offer excellent reproducibility when scaling up and provide an accurate and easy means of forecasting the performance of larger Silverson machines under full-scale working conditions.

The Silverson L5 Series is the latest development in High Shear Laboratory mixing, ideal for all routine laboratory work, research and development, QA analysis and small scale production in all industries.

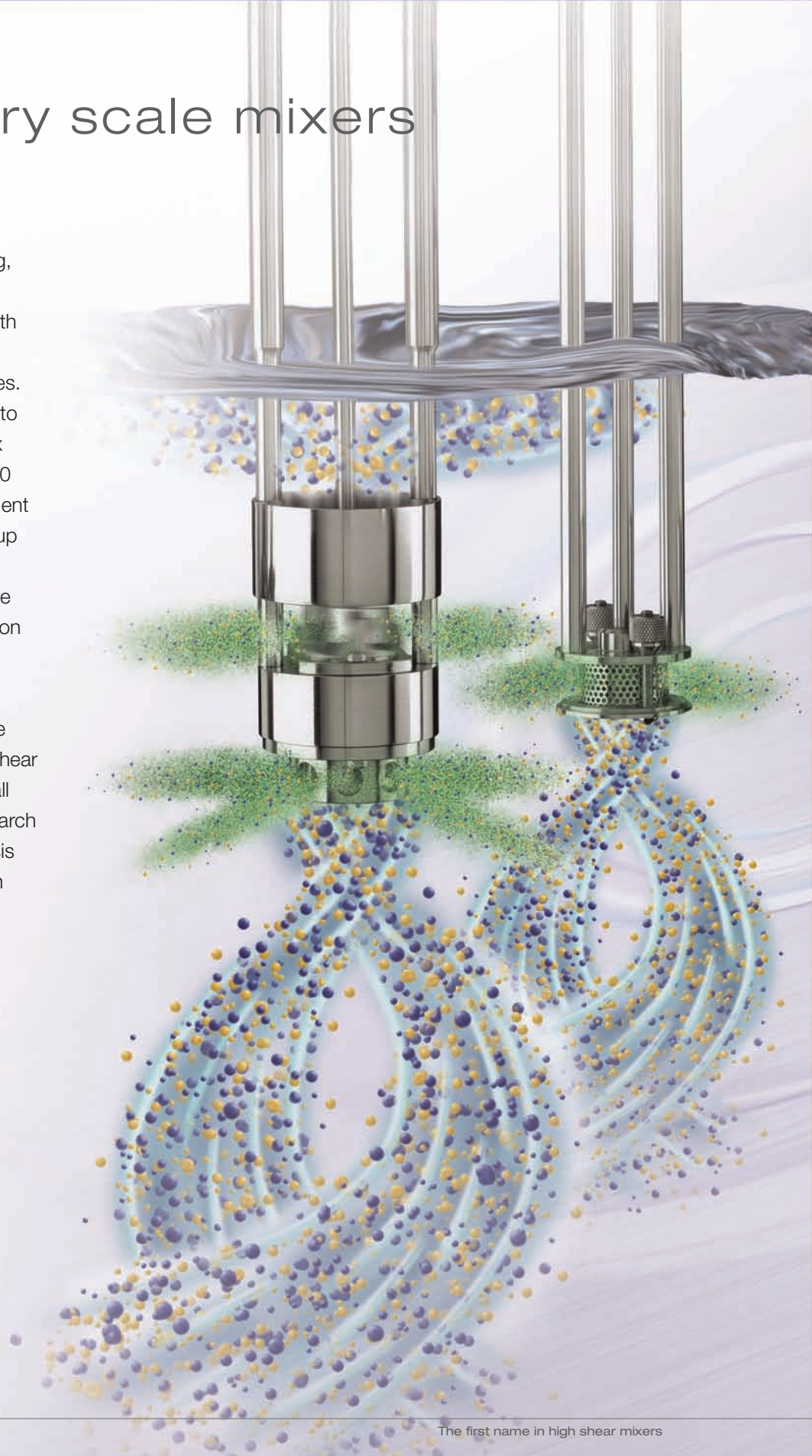



## L5 Series mixers

### L5M Mixer

The multifunctional L5M Model features touch pad control with digital tachometer, programmable integral timer and amperage display, all accessed via the Mode button. This level of instrumentation is invaluable for applications where process validation and reproducibility are required.

### Motor unit

Motor 250W (0.33hp) 220 volt, single phase (110 volt optional), 50/60 Hz. Nominal maximum speed 8000 rpm (6000 rpm under full load).

### Speed control

Infinitely variable electronic speed control with integral on/off switch.

### Electric rise & fall bench stand

The mixing unit may be effortlessly raised and lowered using the touch pad controls on the motor unit.

### Construction

All wetted parts are in grade 316 stainless steel with the exception of the bush which may be bronze alloy or PTFE.

The L5 is finished in a tough, easy to clean, non-chip white nylon coating. The flat base is covered by a removable non-slip solvent-resistant mat.

### L5T Mixer

Similar to the model L5M but supplied with tachometer only.

### L5M-A Mixer

As model L5M but fitted with a more powerful 750W (1hp) motor. The L5M-A can be connected to a computer via USB port for use with the Silverson "DataLogger" program, allowing monitoring and recording of speed and power draw during operation.

### Interchangeable mixing assemblies

Standard assembly (two arm) supplied complete with a General Purpose Disintegrating Head, Square Hole High Shear Screen, Standard Emulsor Screen and Axial Flow Head.

Slotted Disintegrating Heads, Fine Emulsor Screen, Pump Heads and other special heads are available as optional extras, see overleaf.

Capacity - depending on viscosity - up to 12 litres. Mixing unit dimensions – length 290mm (11 1/2"), width 57mm (2 1/4").



## Mixing assemblies

### **Duplex assembly**

The Duplex comprises two workheads facing in opposite directions. The upper head pulls materials down from the surface of the mix, and provides a coarse disintegrating action, while the lower head draws material up from the base of the mixing container, further reducing particle size to accelerate solubilisation or suspension.

This combined use of two workheads makes the Duplex ideal for high viscosity mixes and applications where light or buoyant material (powders, rubbers and polymers, etc.) needs to be drawn down from the surface of a mix and rapidly dispersed.

### **Typical applications**

- Rapid solution of rubbers and polymers for the production of lubeoils, adhesives and bituminous compounds
- Disintegration and dissolving solid resin for varnishes
- Vegetable and meat purée/slurries

### **Tubular mixing assemblies**

A series of interchangeable tubular mixing units suitable for use in narrow-necked containers is available, with capacities from 1-500ml.

#### **1" tubular**

Capacity, depending on viscosity, 50ml up to 500ml.

#### **3/4" tubular**

Capacity, depending on viscosity, 20ml up to 250ml.

#### **5/8" micro**

Capacity, depending on viscosity, 5ml up to 50ml.

#### **3/8" mini-micro**

Capacity, depending on viscosity, 1ml up to 10ml.

### **Ultramix**

The Silverson Ultramix is designed for applications which are beyond the capabilities of a conventional agitator or stirrer but do not necessarily require the intense high shear of a Silverson rotor/stator mixer.







### **In-Line mixing assembly**

The In-Line assembly fits on to the model L5 Series Laboratory range and converts it into an in-line mixer/homogeniser.

The centrifugal action of the rotor in the high shear rotor/stator workhead generates a non-positive pumping action which

gives a throughput on low viscosity liquids of approximately 20 litres/minute, reducing as the viscosity increases.

The In-Line assembly is suitable for use at atmospheric pressure only. It is not suitable for use on abrasive, corrosive or flammable materials.

## Specialised mixers

### **L5 Sealed unit laboratory mixer**

Designed for research in the pharmaceutical and biotechnology fields, the L5 Sealed Unit allows sterile or highly infected tissues to be handled under conditions of absolute safety.

The Sealed Unit features a Quick-Release mechanism permitting use with a wide range of mixing assemblies.

### **Mixing vessels**

Glass vessels with capacities from 7ml up to 1 litre are available. Stainless steel vessels are available with volumes from 1 - 10 litres.

### **Operation under vacuum**

Special sealed mixing assemblies are available for operation under vacuum.

### **Model L2/Air (Compressed air)**

Suitable for use in Atex Zoned/ Explosion Hazard areas. The L2/Air is powered by a 0.25 hp, 6000 rpm variable speed air motor. The L2/Air will accept all L5 Series mixing assemblies. Supplied with a manually operated adjustable bench stand.

## Pilot scale mixers

### **AX series**

This series of mixers is designed for small-scale production in pilot plants, research institutes, hospital pharmacies, etc. Light and easily operated, AX series models have a capacity of up to 50 litres.



#### **Model AX5**

The AX5 features touch pad controls and is compatible with Silverson's "DataLogger" system.

#### **Motor**

Powerful 0.75 kW (1 hp) 220 volt single phase motor (110 volt optional) 50/60 Hz.

#### **Speed control**

Infinitely variable speed control. Nominal maximum speed 6000 rpm.

#### **Electric Rise & Fall Stand**

The unit features an integral rise and fall stand with touch pad controls.



#### **Model AX3**

The Model AX3 features a fixed speed 0.25kW (0.33hp), 3 phase, IP55/Hoseproof, TEFV or ATEX approved Flameproof industrial motor. Variable speed available via an inverter as an optional extra.

More powerful motors allowing a maximum speed of up to 6000 rpm also available.



#### **Model AX/Air**

The Model AX/Air is powered by an intrinsically safe compressed air motor suitable for use in Atex Zoned/Explosion Hazard areas.

#### **Bench stand**

Spring assisted or electric rise and fall bench stands are available for use with the AX3 and AX/Air models.



## Verso - pilot scale In-Line mixer

The Silverson Verso is a bench top In-Line mixer ideal for laboratory or pilot scale applications. The unit offers excellent reproducibility when scaling up and provides an accurate and easy means of forecasting the performance of larger In-Line mixers under full-scale working conditions.

The Verso is equipped with a digital tachometer, ammeter and programmable timer, invaluable for applications where process validation and reproducibility are required. It is also compatible with the Silverson "DataLogger" program.

### Features

- Touch pad control panel.
- Powerful 0.75 kW (1 hp) motor with infinitely variable speed control.
- Single or multistage interchangeable workheads available.
- Self-pumping.
- Maximum operating pressure 100 psi (7.6 bar).
- 0.5" Tri-clamp inlet/outlet connections.
- Single mechanical shaft seal.
- All wetted parts are in grade 316L stainless steel.
- Hygienic construction.

### Advantages

- Eliminates agglomerates and fish eyes.
- Creates stable emulsions and suspensions.
- Reduces particle size.
- Rapidly dissolves solids.
- Accelerates reactions.
- Aeration free.
- No bypassing.

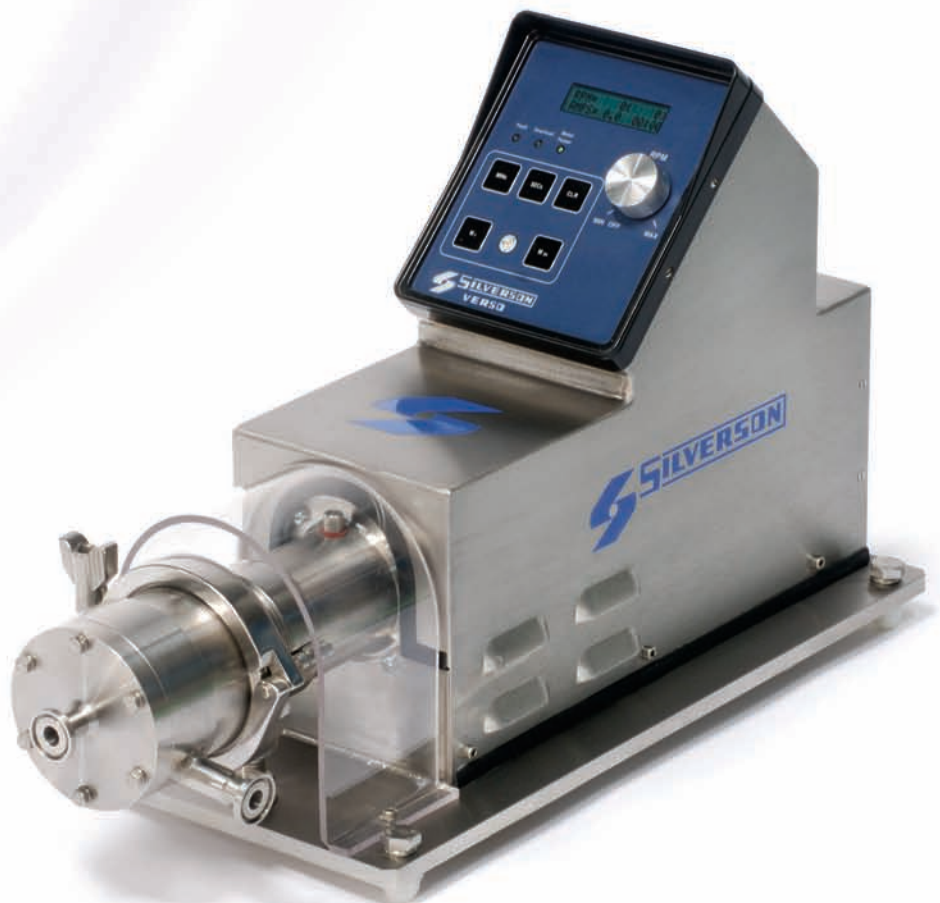

## Batch mixers

Silverson offers a complete range of multipurpose batch mixers. The machines are able to perform the widest variety of applications - mixing, emulsifying, homogenising, disintegrating, dissolving - with an efficiency and flexibility unmatched by other machines. Capacities from 5 to 30,000 litres.

The Silverson range of High Shear Batch mixers are of robust and simple construction, which ensures that cleaning and maintenance is kept to an absolute minimum. The range can be divided into two distinct categories – Medium range and Large range models.

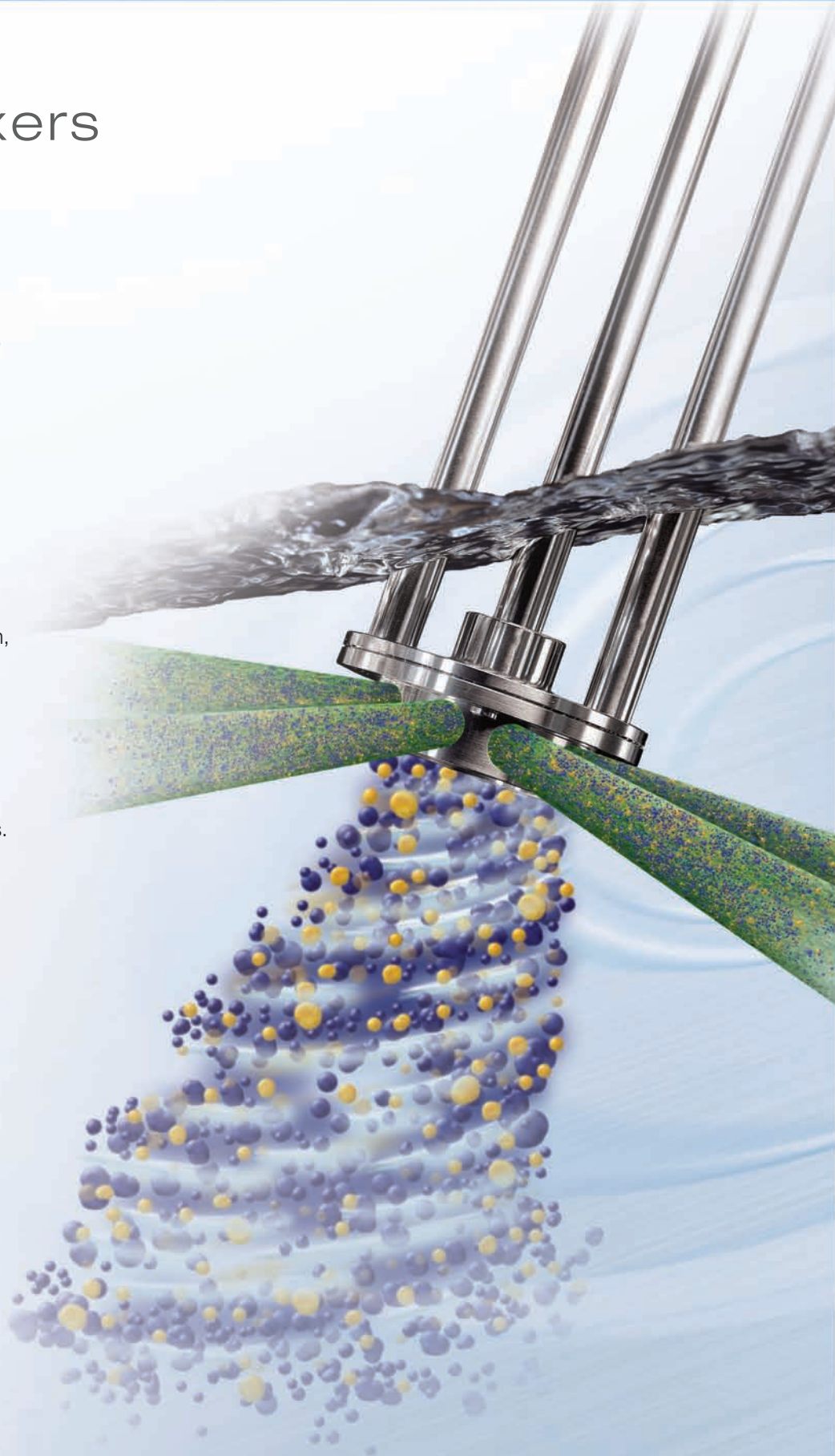



## Medium range – Models BX to GX20

Each machine employs the special “interchangeable” Silverson rotor/stator mixing head, which allows it to be used on a wide variety of different products.

Any machine in this range from the 0.75kW BX to the 15kW GX20 can be used on a mobile hydraulic floor stand (local safety regulations permitting). This option greatly increases the flexibility of these mixers, allowing them to be moved from vessel to vessel and to be raised and lowered during operation, if required, in order to give the optimum mixing position at varying stages of the process.



## Large range – Models 700X to MX

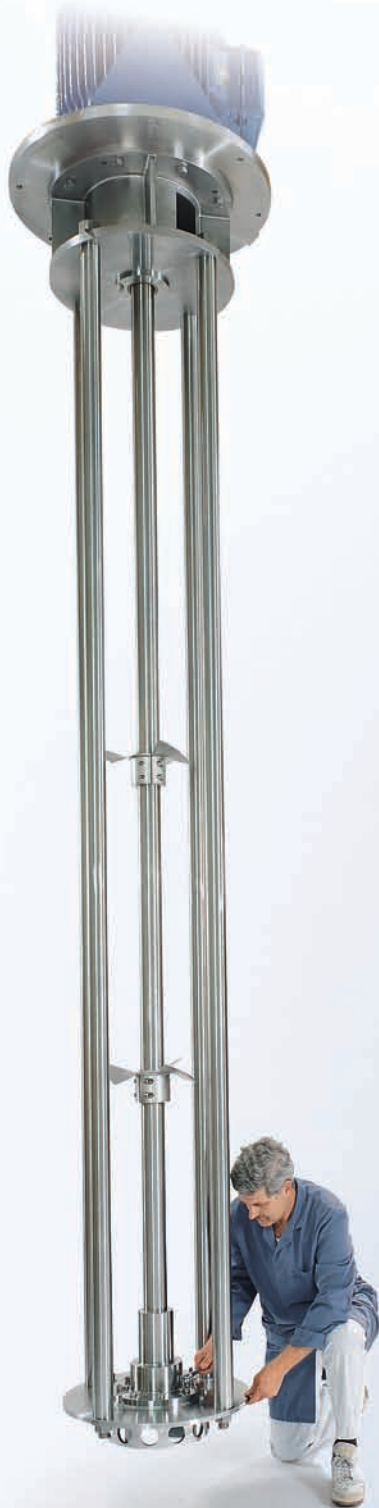

Silverson is the world leader in the specialised design and manufacture of large scale rotor/stator mixers with a capacity of up to 30,000 litres. All these machines are individually built to order and constructed specifically to suit each customer's requirements.

The large scale mixers possess all the qualities and flexibility of Silverson's medium range models and include a number of additional and unique features.

Each mixer is designed and built to the highest possible engineering standards. From the specially balanced motors to the fitting of precision ground shafts which are finish turned in-house to ensure critical vibration free running, no aspect of manufacture escapes our rigorous inspection.

These machines are designed to be maintained and serviced in-situ wherever possible. Quick release shaft couplings, split two-part downthrust propeller and hard-surfaced sacrificial shaft journal sleeves are just a few of the features designed to keep maintenance and downtime to a minimum.

In every case Silverson's technical staff will ensure that the customer's needs are precisely catered for.

# Technical specifications

## Materials of construction

All wetted parts in 316L stainless steel. Special materials on request.

## Bush material

The bush will normally be bronze alloy or reinforced PTFE depending on the application.

## Motors

TEFV (Totally Enclosed Fan Ventilated) and ATEX approved Flameproof motors are available as standard. Inverter rated, stainless steel and other motors are available as optional extras.

## Mounting

Models BX up to GX can be mounted on mobile hydraulic floor stands. Alternatively they can be supplied with either a rectangular or circular flange for mounting on the vessel. Tri-clamp mounting is also available. Larger machines (Model 700X and above) require vessel mounting.

## Sealing

All Silverson Batch mixers are designed for operation in open vessels. Single and double mechanical shaft sealing for operation under vacuum and/or positive pressure is available for most machines

## Cleaning

The machines are in most cases self-cleaning, a short run between successive operations in water, detergent or an appropriate solvent being all that is necessary. For more thorough cleaning, dismantling is easy and downtime minimal.



**General purpose disintegrating head**

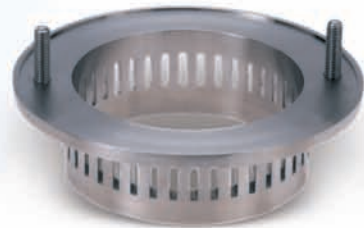

**Slotted disintegrating head**



**Square hole high shear screen™**



**Standard emulsor head and emulsor screen**



## Duplex disintegrator dissolver

The Duplex was specifically developed for the disintegration and solubilisation of solid rubbers and polymers for the lubeoil and adhesive industries, but its success has now seen its introduction into all fields of mixing, whether chemical, pharmaceutical or food.

The Duplex differs from the standard multipurpose batch mixers in having two workheads facing in opposite directions; the upper head pulls materials down from the surface of the mix, while the lower head draws material up from the base of the vessel.

The combined use of two workheads makes the Duplex ideal for applications where light or buoyant material (powders, rubbers and polymers, etc.) needs to be drawn down from the surface of a mix and rapidly dispersed. Because of the added movement afforded by the two workheads the Duplex is also ideal for use on high viscosity materials.

### Typical applications

- Rapid solution of rubbers and polymers into lubricating oils, solvents and bitumen for the production of lubeoils, adhesives and bituminous compounds
- Disintegration and dissolving of solid resin for the production of varnish
- Vegetable and meat purée/slurries
- Recovery of waste confectionery

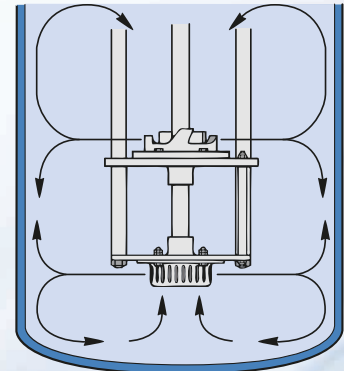

## Specialised mixers

### **Abramix RBX**

#### **No immersed bearing**

With the standard Silverson mixer a highly abrasive product can cause excessive wear on the bush and the shaft. In the Abramix RBX the bush has been completely eliminated by the use of a heavy-duty shaft which is firmly supported by two precision roller bearings, situated above the level of the product being mixed. Minimum maintenance is a key feature of the design.

#### **Dry running**

Dry running in non-flammable products is possible, allowing mixing to continue uninterrupted while emptying the mixing vessel.

#### **Typical applications**

- Liquid Glazes: Preparation and Redispersion including Incorporation of Pigments, Wetting Agents, Hardeners, etc.
- Ceramic slips - Clays and Silicas - Texture Paints
- Foundry Compounds

### **Tubular mixers**

Silverson tubular mixers are designed for operation in sealed vessels where a product-lubricated mechanical shaft seal is required.

Tubular mixers are suitable for operation under atmospheric or positive pressures and are ideal for mixing products where sealant fluids need to be avoided.

The mixer shaft is sealed at its lower end by a conventional mechanical shaft seal which is lubricated and cooled by the product being mixed.

As with all Silverson rotor/stator mixers, interchangeable stators are available to adapt the machine for varying processes.

The tubular design also allows the machine to fit through relatively small diameter vessel openings.

Each mixer is designed to suit individual process requirements.

#### **Typical applications**

- Active ingredients into inhalants
- Injectables
- Vaccines





# Ultramix

The Silverson Ultramix is designed for applications which are beyond the capabilities of a conventional agitator or stirrer but do not necessarily require the intense high shear of a Silverson rotor/stator mixer.

## The advantages

- Ultra hygienic design - single-shaft, single-piece mixing head.
- Designed for Clean-In-Place (CIP) with Sterilise-In-Place (SIP) as an option.
- Full compliance with 3-A TPV (Third Party Verification), USDA and cGMP requirements.
- Rapid incorporation of large volumes of powders.
- Excellent in-tank movement, even when processing high viscosity mixes.
- Low maintenance - no wearing parts or bushes.
- Reduced power requirement.
- Suitable for aggressive chemical service to the most rigorous hygienic requirements.

## Materials of construction

All wetted parts are in 316L stainless steel. Special materials on request.

## Motor specifications

TEFV and ATEX approved Flameproof motors as standard.

## Mounting

Stainless steel flange fitting as standard. Stand mounting for some models is available.

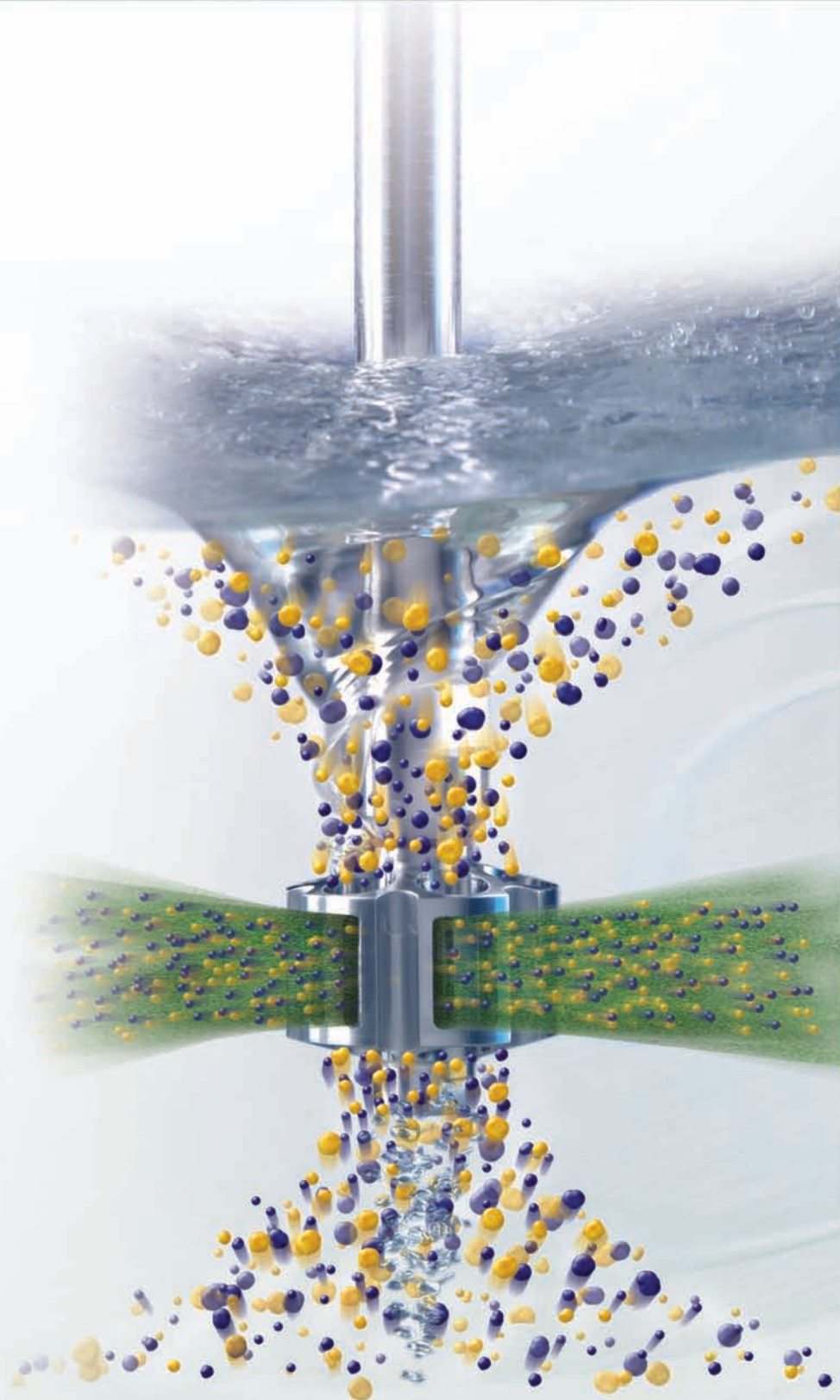



## How the Ultramix works



### Stage 1

As the mixer rotates at high speed, the propulsion grooves on the outside of the mixing head project the surrounding product outwards, creating an area of low pressure outside the head. This draws product from within the mixing head through the radial slots to the outside.

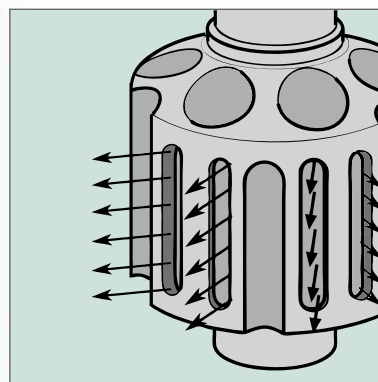

### Stage 2

The material is subjected to a shearing action as it passes through the slots and is projected back into the body of the mix with great force. Fresh material is simultaneously sucked in through the holes in the top and bottom of the mixing head, setting up a vigorous flow pattern throughout the vessel.

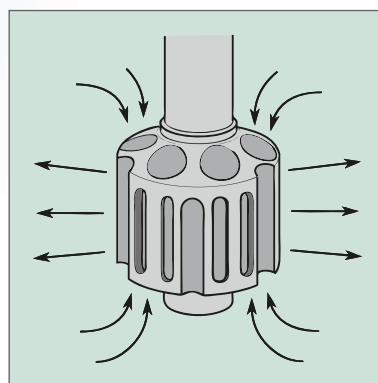

### Mixing Station

The Ultramix is ideal for mixing in problematic containers such as IBCs and Tote Bins - the highly efficient in-tank movement provided by the small diameter workhead overcomes the problems often encountered with difficult vessel geometry. Silverson offers a "Mixing Station" for this type of application equipped with a range of features and options:

- Electric raise and lower mechanism.
- Guarded shaft.
- Vessel proximity sensor and height interlock.
- Optional safety interlocked cage.
- A special hopper allowing powder to be fed directly into the container can be offered for some applications.



## In-Line mixers

Silverson High Shear mixers are supremely efficient and rapid in operation and are capable of reducing mixing times by up to 90%.

The action of any Silverson In-Line mixer can be modified with the use of rapidly interchangeable workheads. This enables any machine to mix, emulsify, homogenise, solubilise, suspend, disperse and disintegrate solids.

- Aeration free
- Self-pumping
- No bypassing
- Interchangeable workheads
- Hygienic construction
- Easy maintenance
- Lower power requirements
- Eliminates agglomerates and fish eyes
- Creates stable emulsions and suspensions
- Reduces particle size
- Rapidly dissolves solids
- Accelerates reactions



## How the In-Line works

### Stage 1

The high speed rotation of the rotor blades within the precision machined mixing workhead exerts a powerful suction, drawing liquid and solid materials into the rotor/stator assembly.

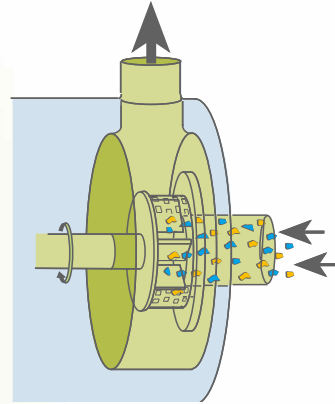

### Stage 2

Centrifugal force then drives materials towards the periphery of the workhead where they are subjected to a milling action in the precision machined clearance between the ends of the rotor blades and the inner wall of the stator.

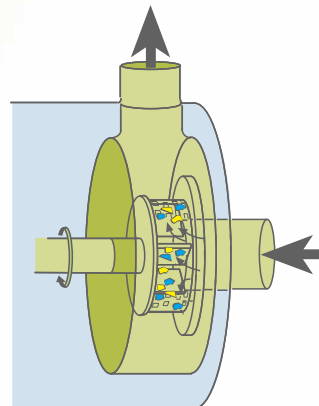

### Stage 3

This is followed by intense hydraulic shear as the materials are forced, at high velocity, out through the perforations in the stator, then through the machine outlet and along the pipework. At the same time, fresh materials are continually drawn into the workhead, maintaining the mixing and pumping cycle.

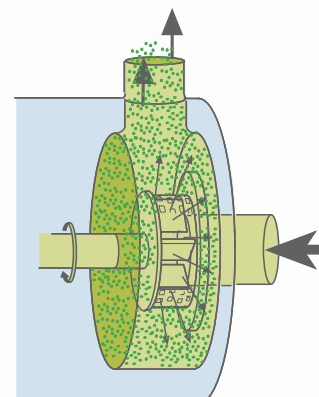



## Ultra Hygienic In-Line mixers

The Silverson UHS series of Ultra-Hygienic multipurpose In-Line mixers is able to perform the widest variety of applications - mixing, emulsifying, homogenising, disintegrating and dissolving - with an efficiency, flexibility and hygienic construction unmatched by other machines.

**EHEDG** and **3-A TPV** (Third Party Verification) Certified and designed to comply with **FDA** and **cGMP** guidelines, these machines are ideally suited for industries where advanced Clean-In-Place (CIP) and Sterilise-In-Place (SIP) facilities are required. The design offers further versatility with multistage rotor/stator configurations as standard options, resulting in substantially faster mixing times by reducing the number of recirculation passes required, and offering greater particle size reduction.

### **Features:**

- Interchangeable workheads with single or multistage configurations.
- Ultra Hygienic **EHEDG** Approved single mechanical shaft seals, easily converted to Ultra Hygienic **EHEDG** Approved double mechanical shaft seals.
- Outlet can be configured for self-venting vertical outlet or rotated to tangential self-draining position.
- Designed for Clean-In-Place (CIP) and Sterilise-In-Place (SIP) operation.
- Self-pumping.
- Aeration free.
- Crevice-free construction.
- No metal-to-metal contact.
- No castings - no porosity.
- All 316L stainless steel construction of wetted parts.
- No manual dismantling and cleaning is required, significantly reducing maintenance, operating costs, increasing reliability and increasing productivity.



# Advantages

## Hygienic construction

**EHEDG** and **3-A TPV** (Third Party Verification) Certified and designed to comply with **FDA** and **cGMP** guidelines, these machines are ideally suited for industries where Cleaning In Place (CIP) procedures are the norm. Not only do these include the food, pharmaceutical and cosmetic industries, but also more diverse applications where modern manufacturing techniques and maximum equipment utilisation require a rapid changeover from one product to another.

## Interchangeable workheads

Available to adapt the machine for varying processes. Changing from one head or screen to another is quick and simple.

## Speed

Adding a Silverson In-Line mixer to an existing process can cut mixing times by up to 90% compared with conventional agitators and mixers.

## No by-passing

The In-Line mixer's design makes it physically impossible for any materials - liquid or solid - to pass from the inlet to the outlet without being subjected to intense mechanical and hydraulic shear as it passes through the rotor/stator workhead. By-passing is impossible.

## Aeration free

As the In-Line mixer and associated vessel and pipework form a closed system, the mixing process is completely aeration free. This is particularly important for applications where air entrainment creates a problem.

## Lower power requirements

As the mixer's energy is concentrated on processing the small volume of material inside the workhead at any given moment, power is not wasted moving large volumes of liquid and consequently less power is normally required than for the equivalent batch mixer. This is particularly beneficial when processing large volumes of material.



## How to use the In-Line mixer

### **Recirculation method**

This is the most common way of using an In-Line mixer, providing a higher degree of homogenisation and particle size reduction. Here product is drawn from the bottom of the vessel, processed through the high shear rotor/stator workhead and passed back into the top of the vessel.

In small vessels this will ensure adequate in-tank movement but in larger vessels an auxiliary in-tank mixer or agitator will be required.

Additional fluid ingredients can be fed into the workhead and uniformly mixed before entering the vessel.

Where quality assurance (QA) demands a set number of passes through the rotor/stator workhead, product can be passed back and forth between two separate vessels.

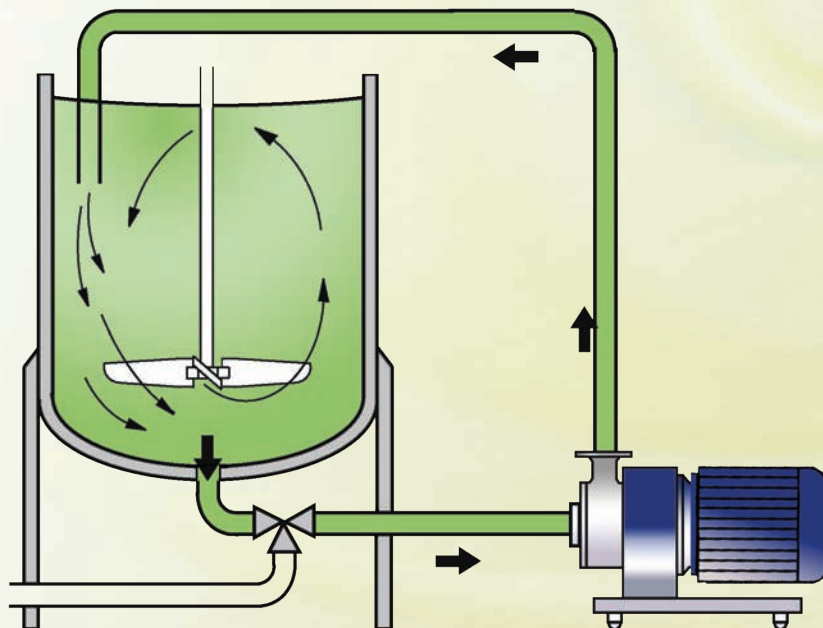



### Single pass method

There are basically three types of operations for which single pass processing can be used.

### Continuous blending

Ingredients are metered into the mixer or a manifold just prior to the rotor/stator workhead. This ensures that products that react together are mixed immediately on contact. This method is ideal for continuous liquid/liquid blending and for products where aeration must be avoided, e.g., detergents.

### Series processing

In cases where a higher degree of homogenisation or comminution is required than can be obtained by a single pass through the In-Line mixer, it is possible to achieve the required results by using two or more machines in series.

### Premix method

The ingredients are coarsely premixed in a holding vessel with a Silverson Batch mixer, Ultramix or a simple agitator. A single pass through the In-Line mixer will then ensure an agglomerate-free homogeneous product. All the product must pass through the In-Line mixer's rotor/stator workhead as bypassing is impossible.

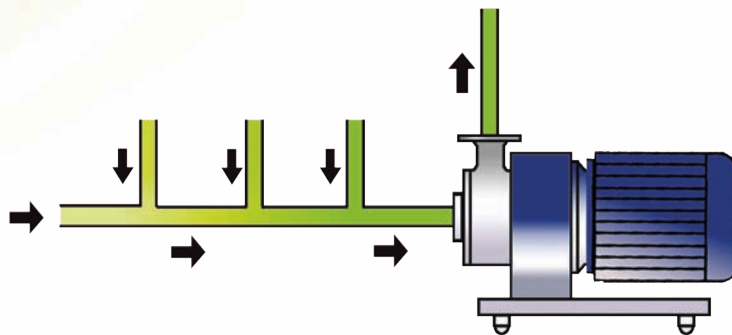

## Technical specifications

### Materials of construction

Product contact parts in 316L Stainless Steel. Special materials on request.

### Motors

TEFV (Totally enclosed Fan Cooled) and ATEX approved Flameproof motors are available as standard. Inverter rated, stainless steel and other motors are available as optional extras.

### Operating pressures

All Hygienic Multipurpose models are designed for operation on pressures of up to 150 psi (10 bar). Higher pressure units are available on request.

### Inlet and outlet connections

All standard sanitary screw or flange fittings are available on request (e.g. ISS, DIN, RJT, SMS, Tri-clamp, etc.).

### Interchangeable workheads

Single stage rotor/stator configurations as standard. For those applications which require greater shear, interchangeable multistage configurations can be used.



General purpose disintegrating head



General purpose disintegrating head, multistage inner and outer



Slotted disintegrating head Emulsor screen



Slotted disintegrating head, multistage inner and outer Combined configuration: inner



Square hole high shear screen™



general purpose with outer slotted disintegrating head



Combined configuration: inner slotted with outer square hole high shear screen™

## General duty In-Line mixers

Silverson offers a range of In-Line mixers suitable for hazardous and aggressive chemical service.

These units are of robust and simple construction which ensures that maintenance is easy and downtime minimal.

With some of the highest rotor tip speeds and shear rates in the industry, production times can be cut by up to 90%, reducing mechanical wear and maintenance requirements while offering better particle size reduction, emulsification, rapid solubilisation and dispersion.

### Optional features

- Jacketed units for temperature sensitive products.
- Non-standard materials of construction such as hastelloy, titanium and hardened steels for processing highly abrasive or corrosive products.
- High capacity units with self-pumping capacities from 220 litres up to 300,000 litres per hour.

### Typical Applications

Bitumens, Edible oil refining, Drilling Muds, Adhesives, Luboils, Pigment dispersions, Titanium dioxide, etc.





## Flashmix powder/liquid mixer

Silverson has over 60 years experience in powder/liquid mixing and offers mixers for a wide range of materials and batch sizes.

The new Silverson Flashmix brings together Silverson's innovative design philosophy with tried-and-tested methods to provide a simple, effective and low-cost solution to some of the most challenging powder/liquid mixing applications.

### **Advantages**

- **Fast powder incorporation rate of up to 5,000 kilos/hour.**
- **Agglomerate-free, consistent product, time after time.**
- **Designed for Cleaning-In-Place (CIP).**
- **Hygienic - the Flashmix incorporates an EHEDG and 3-A Certified hygienic mixer.**
- **Low-level, ergonomic design.**
- **Low power requirement; the Flashmix requires no additional pump.**
- **Simple - the Flashmix is easy to install, easy to operate and easy to clean.**

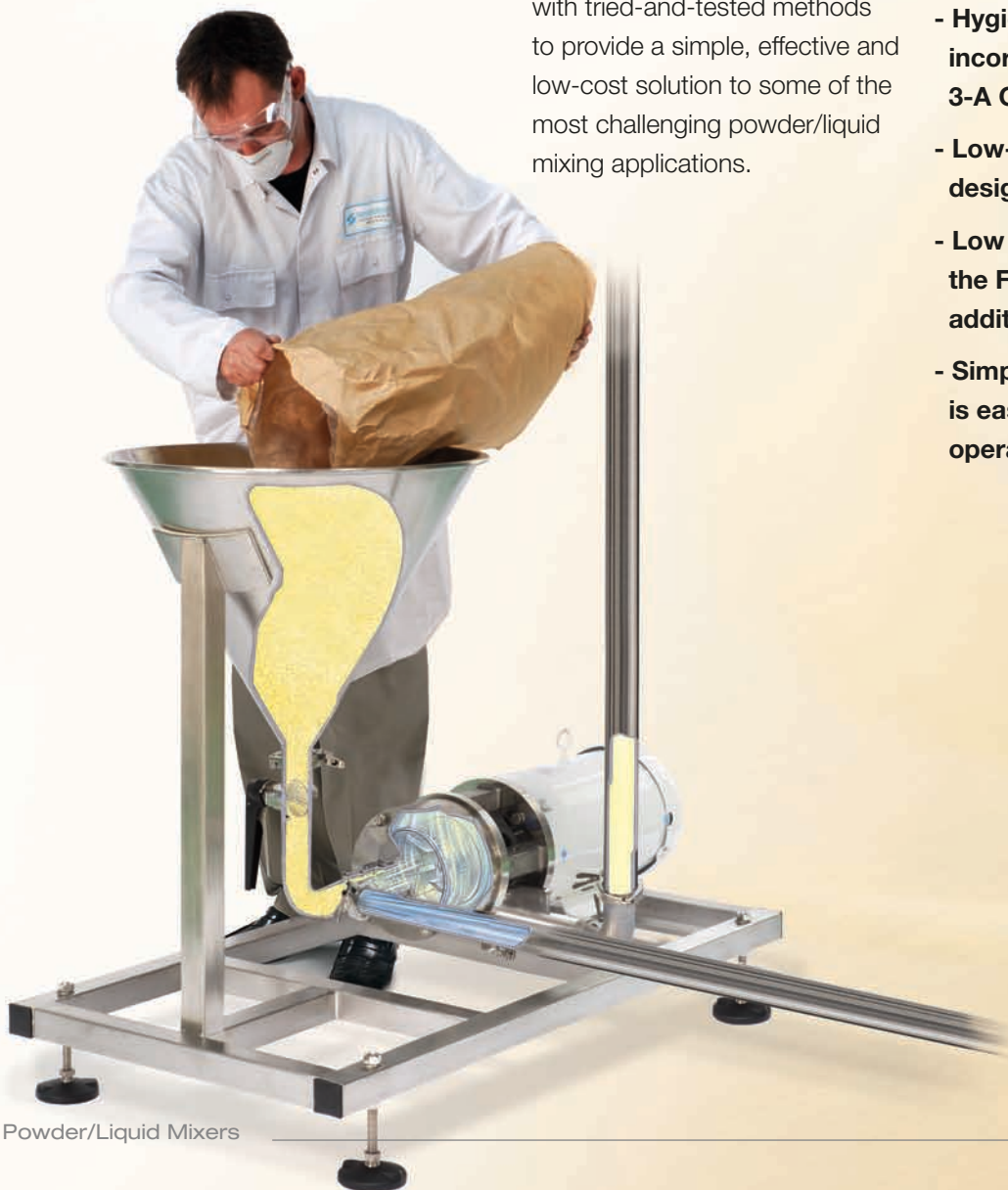

Powder/Liquid Mixers



## Technical specifications

The Flashmix is ideally suited to applications in the Food, Cosmetic and Pharmaceutical industries. The range comprises two models, each available with or without a stainless steel sack table.

### Materials of Construction

All product contact parts are in 316L stainless steel. The chassis is constructed from 304 stainless steel.

### Motor specifications

TEFV (Totally Enclosed Fan Ventilated) motors are available as standard. Other types of motor and enclosures are available as options.

### Inlet and outlet connections

Tri-clamp fitting as standard. Other fittings on request.

### Sealing

Hygienic single mechanical shaft sealing is standard. Double mechanical shaft seals are available.

### Valves

Manual butterfly valves are standard.

### ATEX

Units suitable for use in Zone 22 areas are available.



## Flashblend powder/liquid mixing system

The Silverson Flashblend is designed to incorporate large volumes of powders on a continuous and semi-continuous basis, at rates of up to 15,000 kgs/hour. The system can handle a wide range of viscosities from low viscosity products through to viscous gels.

### **Advantages**

- **Suitable for large scale production.**
- **Easy to incorporate into automated systems including Big Bag discharge units.**
- **Fully sterilisable units available.**
- **Can be customised to suit individual customer requirements.**
- **Agglomerate-free product.**
- **Repeatability.**
- **Speed.**
- **Minimum aeration.**
- **Improved vessel hygiene.**

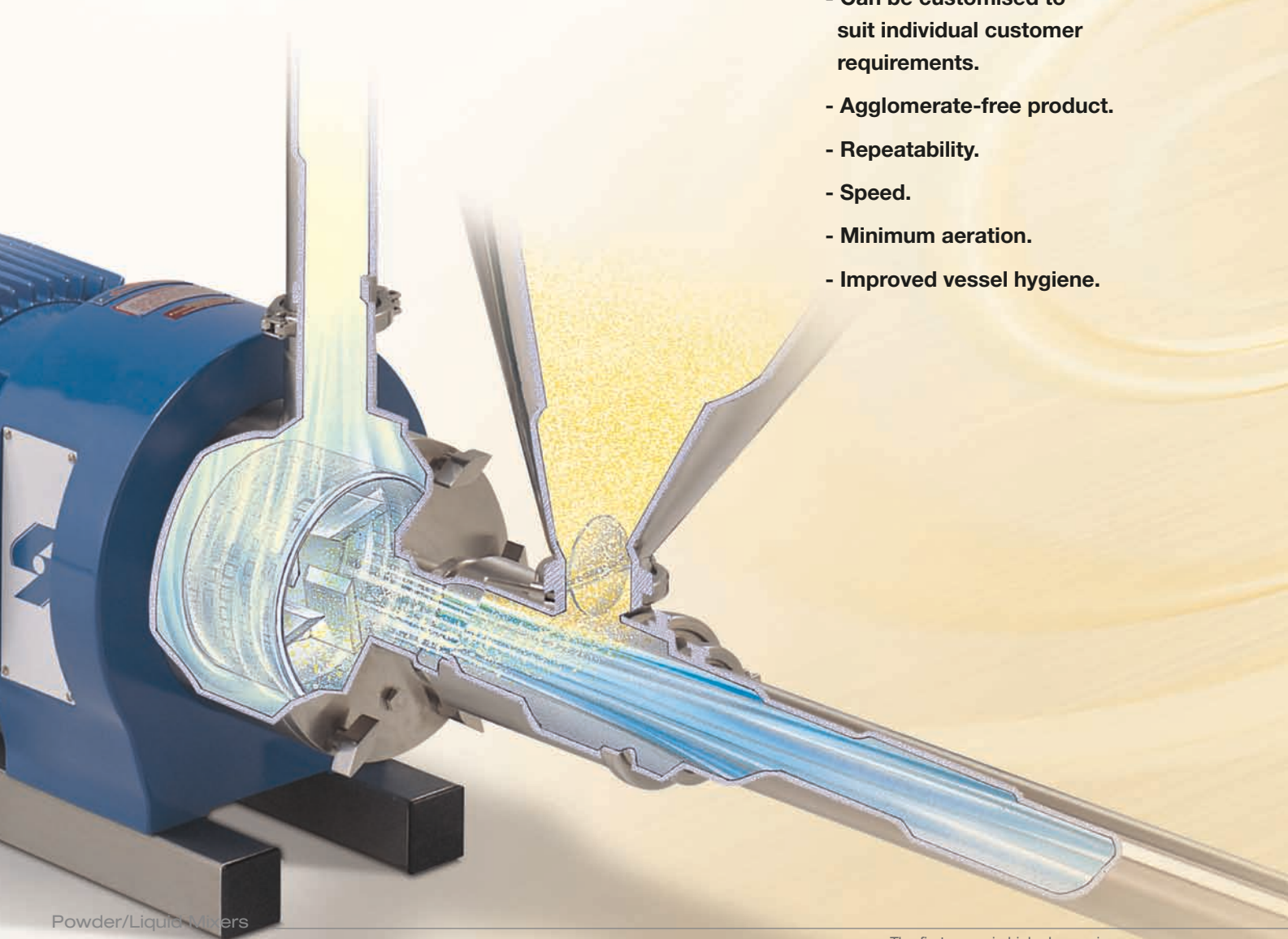



# Flashblend mixing principle

The Silverson Flashblend offers a unique method of incorporating powders into liquids, producing an agglomerate-free and homogeneous product in a single pass.

## Stage 1

The process liquid is pumped at high velocity into the venturi chamber and passes into the In-Line mixer. The combination of the pump, venturi and the pumping action of the In-Line mixer creates a high vacuum in the venturi chamber.

## Stage 2

When powder is present in the hopper, the powder feed valve can be opened. The vacuum rapidly draws the powder down into the venturi chamber where it passes with the liquid stream at high velocity into the rotor/stator assembly of the Silverson In-Line mixer.

## Stage 3

The powder/liquid mix is then subjected to intense mechanical and hydraulic shear which ensures that it is completely dispersed and agglomerate-free. The resultant product is then passed back to the process vessel by the pumping action of the machine.

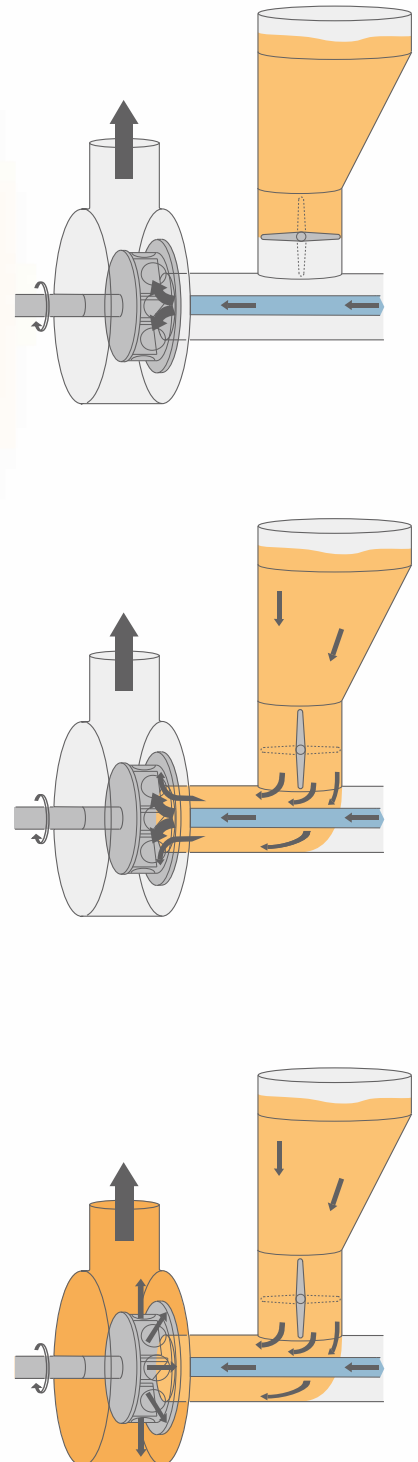

## Flashblend operating sequence

### Operation

Liquid is forced through the Flashblend by the pump (1). The action of this flow through the venturi assembly (2) creates a vacuum which is then boosted by the pumping action of the Silverson In-Line mixer (3). The venturi is separated from the powder hopper (4) by a valve (5) which is controlled by a powder sensor (6). When powder is present in the hopper the valve can be opened and the powder will be drawn down into the venturi by the vacuum.

The powder/liquid mix immediately passes into the high shear rotor/stator assembly of the

Silverson In-Line mixer where it is subjected to intense mechanical and hydraulic shear. This ensures that it is completely dispersed and agglomerate-free. The resultant product is then passed back to the process vessel by the pumping action of the machine. Once the hopper is empty, the sensor will automatically shut the valve, minimising aeration.

Integral with the venturi is a by-pass line (7) which ensures that the venturi area is kept free from any possible powder build-up. When the powder sensor closes the powder feed valve,

a diverter valve (8) is actuated which sends the product around the outside of the venturi nozzle. The flowrate is much higher in this mode than in the powder absorbing mode. This increased throughput ensures a scouring action of the venturi housing and guarantees that the area is kept free of any build-up of partially hydrated powder.

The bypass position is also used for Cleaning-In-Place (CIP). The high throughput exceeds accepted CIP velocities ensuring that the venturi area is cleaned to as high a standard as normal sanitary piping.

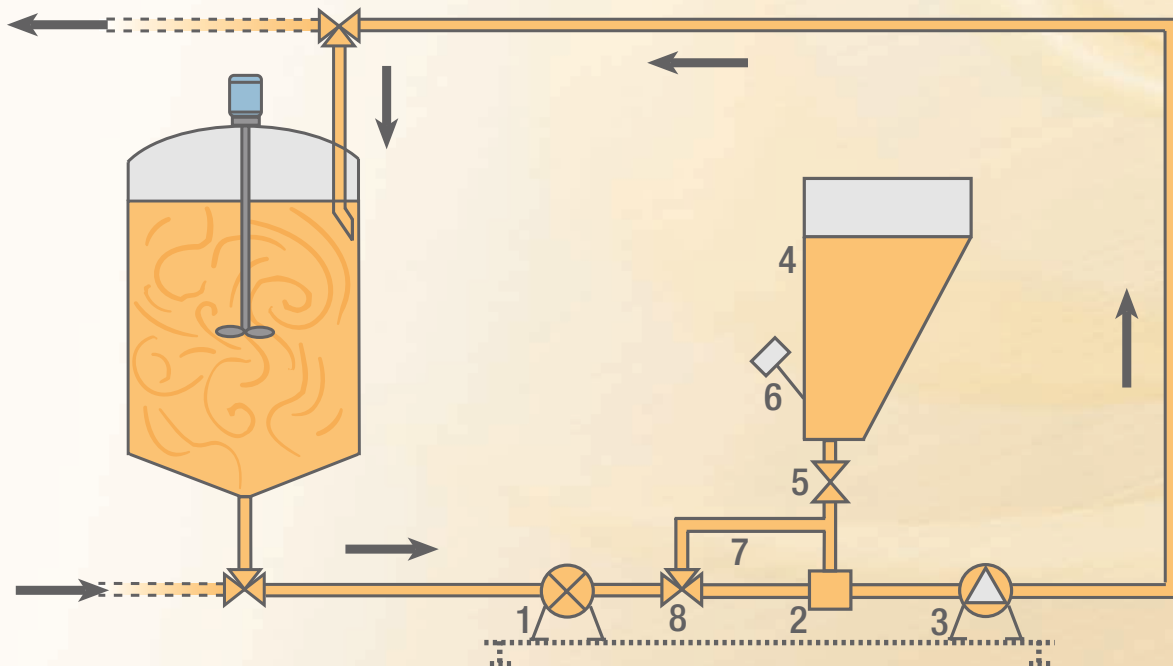

## Advantages

### **Agglomerate-free product**

The combined action of the machine's venturi and High Shear In-Line mixer guarantees a totally agglomerate-free and homogeneous product in a single pass.

### **Repeatability**

Most problems that occur when adding powders into liquids are typically due to operator error - for example adding powders too quickly. With the Flashblend system it is the machine that dictates the powder addition rate, not the operator. Repeatability is assured and a consistent homogeneous product will be produced time after time.

### **Speed**

Powder incorporation rates of up to 15,000 Kgs/hour substantially reduces process times compared with conventional methods of powder dispersion.

### **Minimum aeration**

Careful attention to design and the speed of powder incorporation ensures that aeration is kept to an absolute minimum. Ideal even for products that tend to foam or aerate easily.

### **Installation**

The Flashblend is designed to be installed close to the vessel outlet and at floor level. The low open hopper is easy to charge and this overcomes the traditional problem of having to lift powders to the top of the mixing vessel.

### **Improved vessel hygiene**

All powder is dispersed and hydrated before it enters the mixing vessel, overcoming the build-up of partially hydrated powder on the vessel wall that can be encountered when using an in-tank agitator or mixer to disperse powders.

### **Liquid/liquid mixing**

Viscous liquids can be incorporated into the bulk liquid by adding them via the hopper. This can be achieved without aeration or foaming. Liquid additives can also be pumped directly into the venturi.





## Technical specifications

### **Materials of construction**

All product contact parts are constructed in 316L stainless steel. The chassis is constructed from 304 stainless steel square tube and is used to carry the motor wiring and valve pneumatics.

### **Motor specifications**

TEFV (Totally Enclosed Fan Ventilated) motors are available as standard. Other types of motor and various enclosures are available as options.

### **Inlet and outlet connections**

All standard sanitary screw or flange fittings are available (RJT, ISS, SMS, ASA, DIN, Tri-clamp, etc.).

### **Electrical**

The standard Flashblend has an integral Stainless Steel control cabinet. The panel, switches, lights, etc., are to IP65 and all control voltages are 24V AC. All process functions are controlled from this cabinet which includes a mimic to show the operator the chosen operating mode and the current stage of the process. 460V power requirements are standard; other voltages are available on request.

### **Sealing**

The pump and Silverson In-Line mixer are normally sealed by a single mechanical shaft seal. Double mechanical shaft seals are required when processing products that are abrasive, sticky, viscous or hazardous.

### **Options**

#### **Hopper:**

The inside of the hopper can be coated with food grade nylon to improve the flow of cohesive powders. This finish is not suitable for use in Flameproof areas. Electropolished finish is also available.

### **Powder Feeding:**

The hopper can be modified to accommodate various conveyors, bulk containers, feed systems and dust extraction units.

### **Electrical:**

Facilities to control ancillary equipment can be incorporated in the panel at the design stage.

### **ATEX**

Units suitable for use in Zone 22 areas are available.





## Typical powder dispersion applications

### Food industry:

**Low fat spreads:** Caseinates, Gelatine, Starch, etc.

**Ice cream:** Milk powder, Sugar, Cocoa, Stabilisers, etc.

**Yoghurt:** Milk powder, Sugar, Pectin, Gelatin, etc.

**Baby milk:** Skimmed milk powder, Lactose, Soya protein, Maltodextrin, Fat

**Flavoured milk drinks:** Milk powder, Cocoa, Chocolate crumb, etc.

**Soups:** Starch, Milk powder, Powdered cream, etc.

**Sauces and dressings:** Starch, Xanthan gum, Guar gum, Alginates, CMCs, etc.

**Standardisation of milk:** Milk powder, Lactose

**Sweetened condensed milk:** Sugar, Milk powder

**Jams and preserves:** Pectin solutions

**Pet foods:** Starch, Guar gum, Xanthan gum, Alginates

### Cosmetics and pharmaceuticals:

**Deodorants:** CMC, Active ingredients

**Hair gels:** Carbopol

**Hairsprays and mousses:** Resin into alcohol

**Shampoos:** 70% Sodium Laureth Sulphate (SLES) into water

**Tablet coatings:** Polymer dispersions

**Dental adhesives:** Polymer dispersions

**Contact lens solutions:** Thickening agents, Salts, etc.

**Nutrient broths and media:** Yeast extracts, Proteins, Sugars, Minerals, etc.

**Syrups and linctus:** Sugar, Thickening Agents, Active ingredients

**Oral suspensions:** Thickening agents, Active ingredients

### Beverage and brewing:

**Cream liqueurs:** Caseinates, Sugar

**Soft drinks:** CMC, Pectin, etc.

**Beer:** Head retaining agents, Finings

### Chemical and petrochemical:

**Fumed silicas** into oils, Resins and water

**Specialty chemicals:** Crystalline powders into solvents

**Drilling muds:** Continuous production of Bentonite muds

**Oil Blending:** Incorporation of lime, etc.

### Agrochemicals:

**Suspending agents:** Bentonite, Xanthan gum, etc.

**Dispersion of active ingredients**

## Bottom Entry mixers

Silverson's hygienic series of High Shear Bottom Entry mixers are designed to fit into the bottom or side of a mixing vessel. These high shear mixers are typically used in conjunction with a slow speed anchor stirrer or scraper unit for high viscosity products. The Silverson Bottom Entry mixer gives high shear homogenisation while the stirrer/scraper distributes the homogenised output uniformly through the vessel. This is ideal for high viscosity cosmetic, pharmaceutical and food products.

Bottom Entry mixers can also be used by themselves on low viscosity products and to wet out powders.

Silverson Bottom Entry mixers offer full compliance with USDA and cGMP requirements.

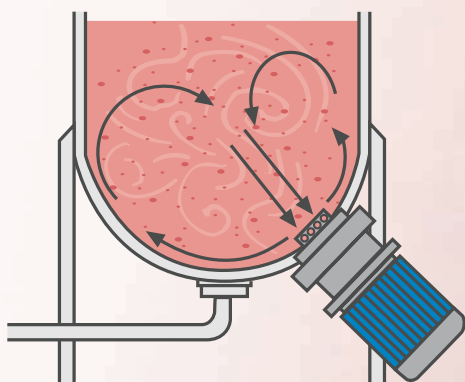
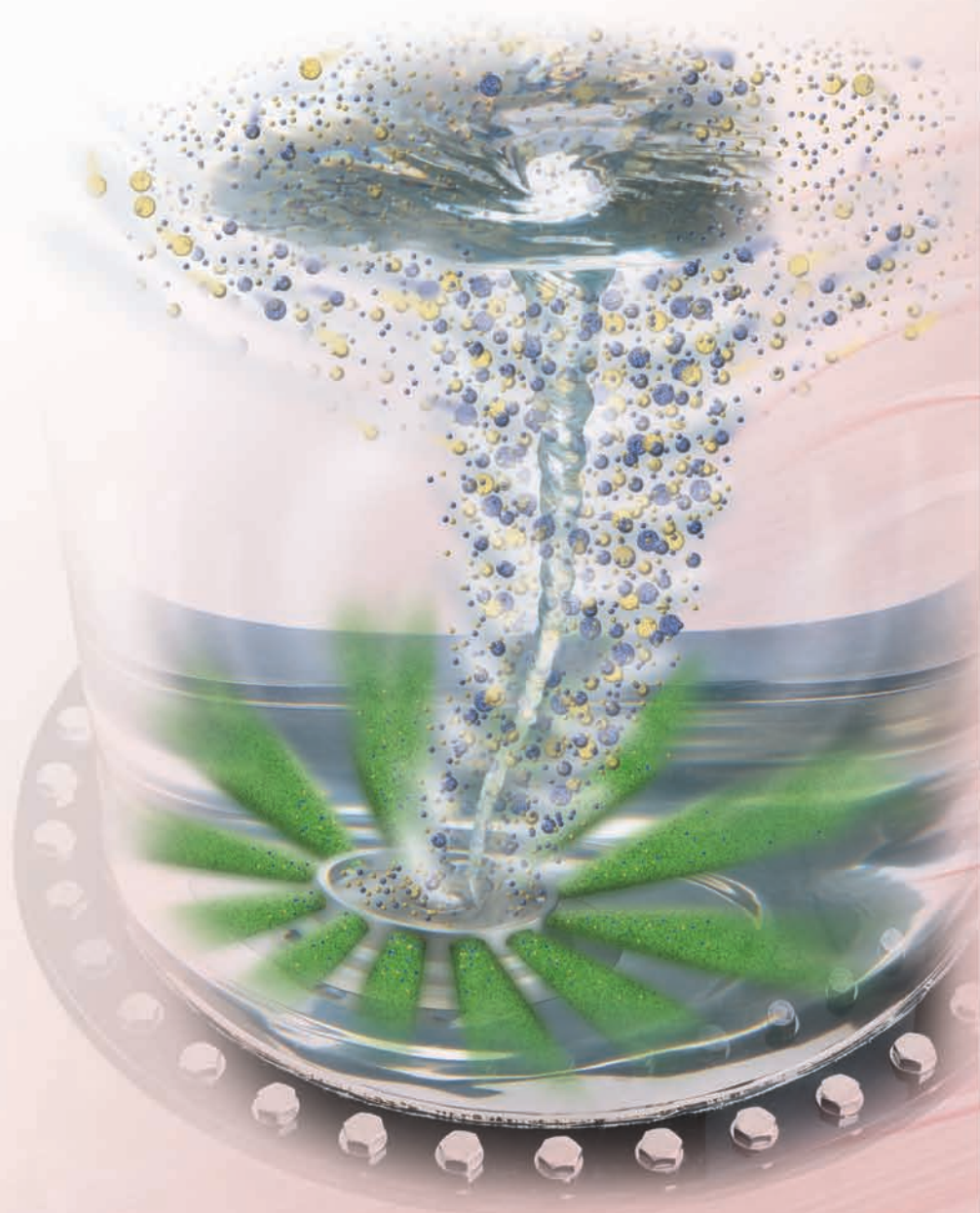



# Technical specifications

## Materials of construction

All wetted parts are in 316L stainless steel. Special materials on request. Electropolished finish is available as an optional extra.

## Motor specifications

TEFV (Totally Enclosed Fan Ventilated) and ATEX-approved Flameproof motors are available as standard. Inverter rated, stainless steel and other motors are available as optional extras. Electrical switchgear or wiring is not supplied.

## Mounting

Stainless steel flange fitting is available as standard. Clamp-on fitting is optional for smaller machines.

## Sealing

Single mechanical shaft sealing: A single carbon/ceramic mechanical shaft seal with viton elastomers is standard. Other face materials and elastomers are available as optional extras.

Double mechanical shaft sealing: These are required when processing products that are abrasive, sticky or viscous or when the system is under vacuum.

Sealant flushing systems can be supplied as optional extras.

## Cleaning

Clean-In-Place (CIP) design. Simple, easy to clean construction.

## Operating pressures

All standard models are designed for operation on pressures not in excess of 40 psig (2.8 bar). High-pressure units are available upon request.

## Ultra hygienic model available with features including:

- Crevice-free construction
- Hygienic metal bellows shaft seal
- Electropolished finish



General purpose disintegrating head



Slotted disintegrating head



Square hole high shear screen™



Emulsor screen

*better mixers, better results*

## Disintegrator 2500

If you thought it couldn't be done think again. Silverson's mighty Disintegrator mixing system will disintegrate, solubilise or disperse the largest of solids - up to 1000mm (40") across - in a single operation and in times you wouldn't believe!

The D2500 incorporates a powerful and unique Silverson mixer located in the bottom of a custom-built vessel. The mixer exerts a massive suction downwards from the surface of the liquid, pulling down even the most buoyant of solids, no

matter what the size. These solids are literally ripped apart and dispersed throughout the mix, and with the refinement of a Silverson In-Line mixer, included in the system, are totally solubilised or suspended.



# How the D2500 works

The D2500 is a self-contained high-powered unit consisting of a specially designed Silverson high shear rotor/stator disintegrating workhead set into a custom-built vessel coupled with a Silverson High Shear In-Line mixer.

## Stage 1.

The unit is charged with liquid and started. Large solids are fed into the vessel and drawn down into the workhead which will rapidly shear lumps and slices off the edges and corners. These will be drawn into the interior of the workhead, driven by centrifugal force to the periphery and further sheared by the rotor tips against the edges of the stator as they are expelled radially from the head.

## Stage 2.

Rapid fragmentation of the large solids continues until all the particles are small enough to be drawn into the workhead for further disintegration. Materials are discharged horizontally from the workhead and forced up the vessel's walls, drawn into the centre vortex and repeatedly through the workhead for final disintegration. This cycle continues until all solids are reduced to granular size.

## Stage 3.

Once the solids are down to granular size the self-pumping Silverson In-Line mixer is started. The product is drawn from the bottom of the vessel, processed through the In-Line mixer's high shear rotor/stator workhead and passed back into the top of the vessel, ensuring complete solution or suspension.

## Stage 4.

Samples may be taken off at any time during the process. When inspection shows that all solids are completely dissolved or suspended, any additives or final additions of solvent to standardise the product may be introduced either into the vessel or into the In-Line mixer loop.

As soon as the product passes inspection and quality control, the vessel may be emptied either through the Silverson In-Line mixer or a separate self-draining outlet.

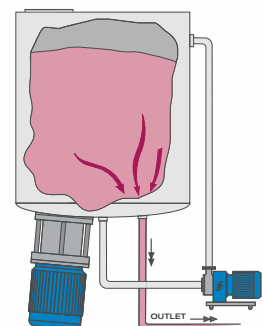
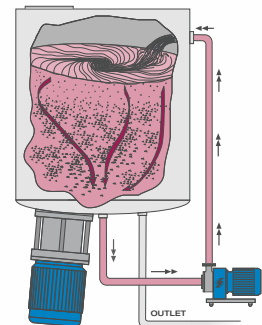
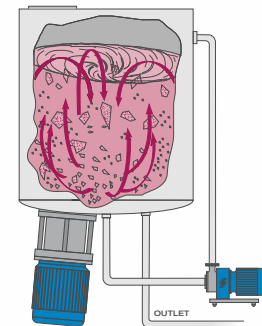
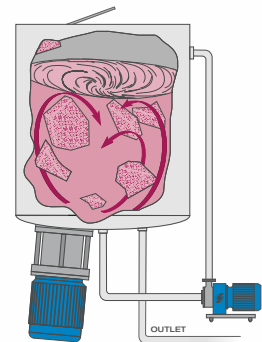



## Advantages

Size and shape of product is inconsequential. The Disintegrator 2500 can take odd shapes and the largest sized polymer bales commercially produced.

- No need for pre-grinding, slicing or cutting of large solids. All solids are dissolved in one vessel.
- Elimination of additional equipment such as grinders or choppers reduces maintenance costs and dust emissions.
- Puts products into complete solution or suspension without leaving undesired particles on vessel walls.
- Can handle poly-wrapped bales without prior removal of wrapper, eliminating the need for cutting and excess waste.

### **Typical Applications**

- Rapid solution of rubbers and polymers into lubricating oils, solvents and bitumen for the production of VM luboils, adhesives and polymer modified bitumen for road surfacing
- Dispersion of filter cakes
- Disintegration of solid blocks of cheese, butter, compressed raisins & dried fruit, oleoresins and frozen meat
- Disintegration and dispersion of animal and vegetable matter
- Wet crumbing of waste rubber
- Disintegration of solid gums, resins and varnishes
- Recovery of waste confectionery



## Further information

A range of detailed Technical Data Sheets is available from Silverson, including performance data, dimensional diagrams and other specifications.

Silverson can also supply a range of Application Reports and Video/CD packages with further information about the company and its products.

All information can be secured by calling your local Silverson representative or by requesting a copy of the necessary information through our website:

[www.silverson.co.uk](http://www.silverson.co.uk)



## **United Kingdom Corporate Headquarters**

Silverson Machines Ltd.  
Waterside, Chesham  
Buckinghamshire HP5 1PQ  
England  
Tel: +44 (0) 1494 786331  
Fax: +44 (0) 1494 791452  
Email: sales@silverson.co.uk

## **United States**

Silverson Machines, Inc.  
355 Chestnut Street  
East Longmeadow, MA 01028  
Tel: +1 (413) 525-4825  
Fax: +1 (413) 525-5804  
Email: sales@silverson.com

## **France**

Silverson France  
12 Boulevard Louise Michel  
91030 EVRY CEDEX  
France  
Tel: +33 (0) 1 60 77 91 92  
Fax: +33 (0) 1 60 77 81 88  
Email: info@silverson.fr

## **Japan**

Silverson Nippon Limited  
Onohara Higashi 4-22-3  
Mino 562-0031  
Osaka-Japan  
Tel: +81-72-734-8003  
Fax: +81-72-734-8004  
Email: sales@silverson.co.jp

**Silverson can be found on the World Wide Web at [www.silverson.co.uk](http://www.silverson.co.uk)**

Silverson® is a registered trademark of Silverson Machines.

Square Hole High Shear Screen™ is a trademark of Silverson Machines.

Patent Pending.