

# INOVAPAK

# NEW

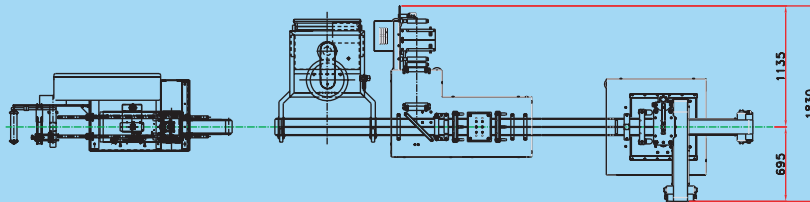
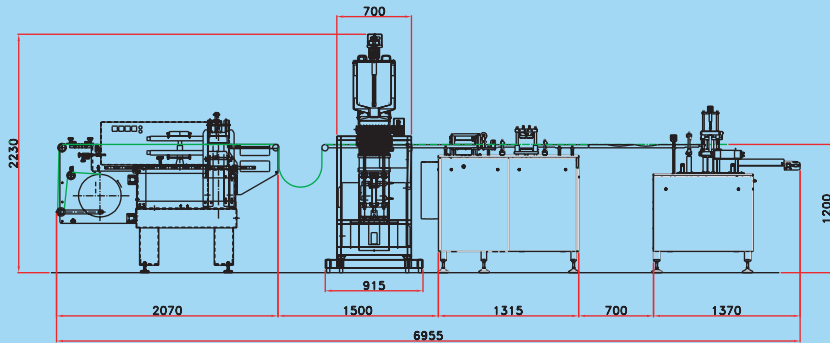

## Dati tecnici linea

- Produzione: da 20 a 25 cicli/min a seconda del materiale plastico utilizzato
- Tensione di alimentazione: 230/400 V, 50 HZ 3 ph+ neutro +terra
- Tensione di comando: 24V cc
- Potenza installata: 15 kw
- Acqua di raffreddamento: 5 l/min.
- Aria compressa: 450 NL/min, 6 bar
- Peso complessivo: 2700 kg

## Technical datas Easy Line

- Production speed/ 20÷25 cycles/min, depending on plastic material utilised
- Standard voltage: 230/400 V, 50Hz, 3 ph+neutral+earth
- Control circuit: 24V DC
- Installed power: 15 kw?
- Cooling water: 5 l/min
- Compressed air: 450 NL/min at 6 bar
- Weight: 2700 kg

## Données techniques Easy Line

- Production: 20-25 cycles/minute, selon le matériau plastique utilisé
- Tension d'alimentation: 230/400 V, 50Hz, 3 ph +neutre + terre
- Tension de control: 24 V DC
- Puissance installée: 15 kw
- Eau de refroidissement: 5 l/min
- Air comprimé: 450NL/min at 6 bar
- Poids: 2700 kg



# EASY LINE FFS

DISTRIBUTED BY  
 **SARONG**  
PACKAGING & MATERIAL DIVISION