

Discharge Aids

Discharge Aids

Discharge Aids



Introduction

Process Components Ltd is the only manufacturer and supplier of the Mucon product range to the liquid powder and bulk solids handling sectors.

- Iris Valves – The Original Mucon Valve
- Slide Valves
- Butterfly Valves
- Disc Valves
- Discharge Aids
- Level Indicators

The Industry sectors we supply include;

- Food Processing
- Pharmaceutical
- Chemical Processing
- Glass and Ceramics
- Plastics
- Sand and Cement



Brands

Process Components Ltd own the intellectual property for the manufacture of spare parts for the following brands;

- Mucon
- KEK – Centrifugal Sifters, Universal Mills, Cone Mills
- Gardner – Blenders and Mixers
- PPS – Air Classifier Mills

Process Components guarantee exceptionally high levels of service and product quality, which you would expect from a genuine spare parts manufacturer.



After Sales and Service

- Full on-site process machine servicing and maintenance
- On-Site inspection, repairs and testing
- Bespoke design service



The Problem

Problems of material flow from storage bins, silos, hoppers etc should not be underestimated.

'Bridging' or 'Rat-Holing' for example, usually occur in the lower region of the hopper. This is because the area near the outlet for most hoppers decreases dramatically, restricting the area for material to flow and causing compaction. As a consequence, getting material to flow often requires various efforts to achieve.

Meanwhile, productivity, production, time, money and effort are all lost trying to get material flowing through the manufacturing process.

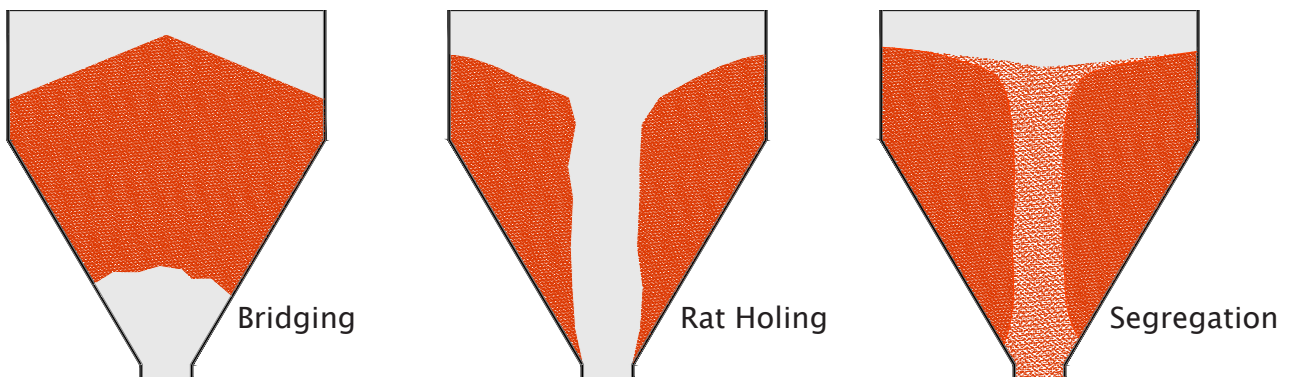

Factors that affect the flow properties of dry bulk solid materials:

- Bulk density (Weight / Unit volume)
- Particle size
- Particle shape
- Cohesive properties
- Moisture content / Hygroscopic properties
- Temperature
- Storage time
- Pressure / weight / vibration

Choosing the correct discharge aid for your application will depend greatly on identifying correctly, several of the above factors.

The Mucon range of discharge aids provides operators the opportunity to easily and efficiently overcome processing problems associated with poor material flow, such as Bridging, Rat-Holing and Segregation.

Mucon offers three distinct Discharge Aid Solutions

Promoflow Discharge Aids, Pages 4-5

- Quick and easy to install
- Can be retrofitted to any existing silo, hopper or bin
- Available in a variety of sizes to suit any size of silo, hopper or bin

Vibrator Discharge Aids, Pages 6-7

- Cost effective discharge aid solution
- Ideal for use in small vessels and chutes
- Can be used to consolidate aerated material in storage bins

Aerator Discharge Aids, Pages 8-10

- Ideal discharge aid for use with dry powders
- Easily installed
- Ideal for keeping powders and slurries 'alive'
- FDA approved contact materials



Promoflow Discharge Aids

'shakes the contents – not the bin'

Promoflow Discharge Aids vibrate the product inside the hopper or silo, but not the structure itself. This prevents the fatigue factors commonly associated with other vibrating discharge solutions.

The custom made internally mounted screens are specially designed to transmit vibration directly into the product, preventing material bridging, rat-holing or segregation during discharge.

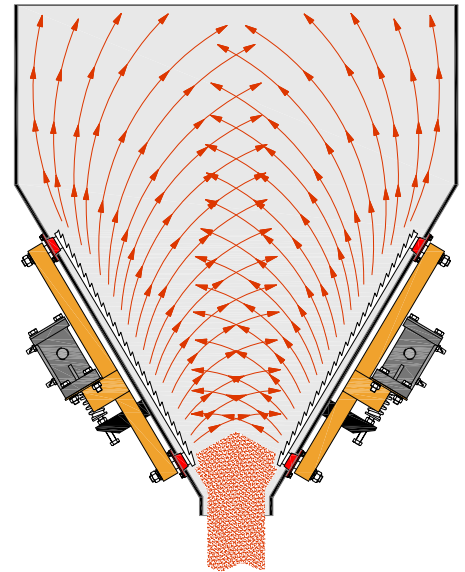

The Promoflow Solution

The installation of a Promoflow discharge system will promote the flow of any product which is normally capable of flow, but which needs occasional or frequent help to get started or to keep material moving.

How Does it Work?

Promoflow discharge systems introduce vibration directly into the product keeping it 'alive', reducing the strength of any bonding or locking of the particles, which may result in a flow problem.

Robust vibrators mounted externally activate vibrating screens mounted on the inside of the silo walls, at the points where flow problems occur. Rubber isolation mounts attach the Promoflow discharge systems to the silo, preventing leakage through the mounting holes. The discharge screen movement is typically 2–4mm which is sufficient to generate a steady action, whilst imparting little or no vibration to the silo itself.

Ideal for existing silos....

The Promoflow discharge system is a quick and easy retrofit solution to existing silos and hoppers. It can be used in conjunction with many different materials and designed to fit most vessels, regardless of their shape or size. They can even be installed in concrete silos

Customer Benefits

- Easy and quick to install retrospectively to existing hoppers and silos
- Can be fitted in any location within a storage vessel where a flow problem exists
- Able to target and control the amount of agitation required
- Shakes the contents not the bin
- Quiet operation
- Low energy consumption
- Well-proven design with many satisfied users in a wide variety of applications

Control Systems

Promoflow discharge systems should only be operated when the product is able to flow out of the silo at a rate greater than the feed rate induced by the vibrating screens.

Some products only require an initial 'nudge' after standing inactive for long periods of time. Other products may require greater assistance to promote flow for example, after a period of damp weather. In addition, there are many products and hopper situations, which require continuous or frequent product agitation to keep material flowing.

Accordingly two basic control packages are offered:

1. Manual on/off
2. Programmed control

The Range

Mini Promoflow discharge systems are designed to fit the smallest of hoppers, bins and feed chutes etc. They are ideal for fitting to hoppers, above tableting presses, metering feeders, extruders etc.

Standard Promoflow discharge systems are a range of general purpose models used in a multiplicity of applications associated with average sized storage vessels and silos.

Super Promoflow discharge systems are designed for the biggest of silos and to cope with the most arduous of applications where the bulk density of vessel contents is high.

The rubber isolation mounts are considerably more robust to accommodate increased loads.



Screens

There are 52 standard screen sizes and shapes, with an infinite number of variations. Screens can be either flat or curved to suit hopper contours. There are two types of screen available: mesh and rib cage. Both screen types can be made from either carbon or stainless steel.

Rib Cage Screens

The screens are high pressure water cut from either carbon or stainless steel plate with variable width ribs to prevent resonance.

Rib cage screens are used for large particles, fibrous materials, and irregular particles in excess of 20mm in diameter.

Mesh Screens

These are manufactured from expanded metal sheet and are stiffened with a metal framework. Mesh screens should be selected for all applications involving powder and granular materials less than 20mm in diameter.

Triangular

Suitable for most cylindrical hoppers when curved to match the contour of the conical section. Triangular screens are also suitable for the converging section of rectangular hoppers. In such cases the screens are flat.

Diamond

Suitable for applications involving high bulk density materials where large areas of vibration are required, but where the loading on a triangular or rectangular screen would be too high. These screens can be flat or contoured as required.

Rectangular

Suitable for use in chutes or flat sided bunkers. In extreme cases of 'bridging' they can be used on the parallel section of hoppers. The screens can either be flat or contoured.

Typical Products Handled....

Foods, Pharmaceutical, Chemicals

Others include:

Asbestos, Wood Chips, Sand, Bauxite, Shredded Paper, Bone Meat, Metal Powders, Fire Clay, Wood Shavings, Coal, Lime, Ore Slag, Glass Frit, Gypsum, Cement, Plaster, Ester, Vermiculite, Metal Slivers etc

Vibrator Discharge Aids

Because of their ultra low noise and high degree of application reliability, the ATU Turbine Vibrator is ideal for internal plant environments or where a low noise solution to your material flow problem is required. By imparting vibration through the hopper wall, the ATU Turbine Vibrator helps to promote product flow.

Applications are varied and include food processing, chemical, plastic processing, foundries and many more.

Product Features & Benefits

- Excellent power to weight ratio
- Easily interchanged with similar competitor products
- Durable finish, anodized aluminium (standard) or painted
- Lower air consumption than comparable air vibrators
- No lubrication required
- Low noise level, 62–78 dBA well below OSHA standards
- Has a temperature rating of 350°F / 176°C



Mounting Information

Bins or Hoppers with a Vertical Slide

The vibrator should be mounted on the sloping side approximately a third of the vertical distance from the discharge opening to the top of the slope.

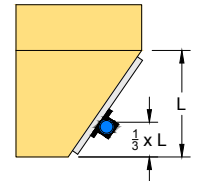

Conical Bins or Hoppers

The vibrator should be located between quarter and third of the distance from the discharge opening to the top of the bin or hopper as shown. If two vibrators are necessary, they should be mounted diametrically opposite, but 6" (150mm) higher than the first vibrator.

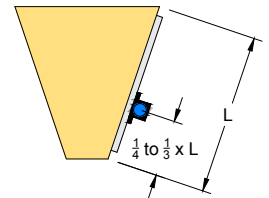

Rectangular Bins or Hoppers

Mount the vibrator on the hopper centre line about quarter to a third of the distance from the discharge opening to the top of the hopper. It is preferable to mount the vibrator discharge aid on a stiffener if one is present. One vibrator is usually sufficient, but if thorough discharging is not attained, first go to a larger vibrator for more impact. Alternatively mount a second vibrator directly opposite and at the same level.

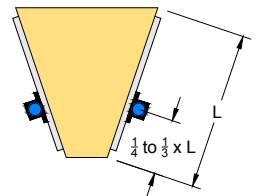

Parabolic Bins or Hoppers

The vibrator should be mounted approximately 12" (300mm) from the discharge opening as illustrated. One vibrator is generally sufficient for each discharge opening.

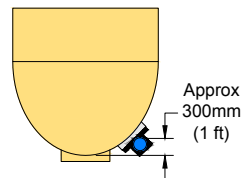

Rectangular Bins with Hopper Discharge

Vibrator mounting is the same for rectangular bins or hoppers as noted above. This type of bin however will usually require more impact.

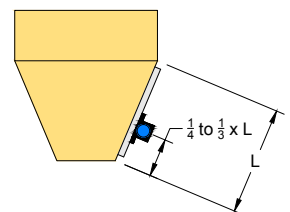

Inclined Chutes

For a steady flow of material, mount the vibrator about a third of the way up from the chute's lower end. If necessary, vary this location to determine best results.

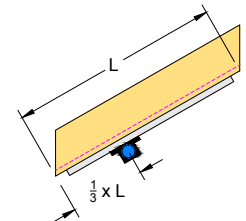

Hints on Model Selection

It is recommended that the vibrator is selected on the basis of material weight in the tapered or conical section of the hopper or bin, in conjunction with the material bulk density. The selection chart below can be used as a guide:

1. Trace a line vertically from the horizontal axis relative to the weight of material
2. Where the line intersects the appropriate coloured series (based on the material bulk density) trace a line horizontally to the vertical axis
3. Where this line intersects the vertical axis read off the vibrator force required

Please note that this is just a guide, our Sales Engineers will be happy to assist with the selection process, especially if more than one vibrator is required.

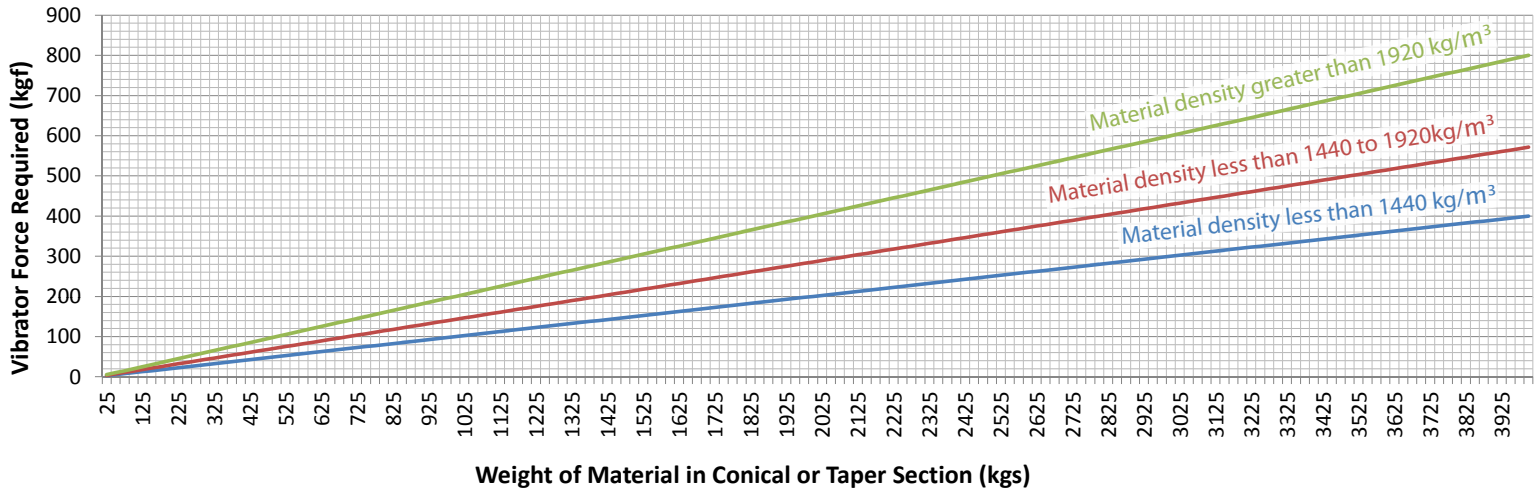

Weight of Material in Conical or Taper Section (kgs)

Model	40 PSI (2.8 bar)						60 PSI (4 bar)						80 PSI (5.5 bar)					
	VPM	Force		Air Consumption		Noise	VPM	Force		Air Consumption		Noise	VPM	Force		Air Consumption		Noise
		lbs	kgf	CFM	m ³ /h	dB (A)		lbs	kgf	CFM	m ³ /h	dB (A)		lbs	kgf	CFM	m ³ /h	dB (A)
ATU-21	26000	154	70	1.8	3.1	68	30000	204	93	2.6	4.4	71	33000	247	112	3.3	6	73
ATU-22	23000	150	68	1.8	3.1	62	27500	215	98	2.6	4.4	64	30000	256	116	3.3	6	67
ATU-23	16000	138	63	1.8	3.1	60	17500	165	75	2.6	4.4	61	19000	195	88	3.3	6	62
ATU-31	18000	212	96	4.9	8.3	67	22000	316	143	6.4	11	67	24000	326	148	8.1	14	68
ATU-32	17000	230	104	4.9	8.3	65	20500	334	152	6.4	11	67	23000	421	191	8.1	14	70
ATU-33	12000	237	108	4.9	8.3	65	15000	371	168	6.4	11	68	16000	422	191	8.1	14	69
ATU-41	13500	316	143	6.7	11.4	67	16500	472	214	9.4	16	67	18500	593	269	11.7	20	69
ATU-42	12000	368	167	6.7	11.4	64	15000	575	261	9.4	16	66	16500	696	316	11.7	20	67
ATU-43							11700	746	338	9.4	16	67	13000	922	418	11.7	20	68
ATU-51	11500	841	381	10.7	18.2	69	13500	1159	526	15.3	26	74	14500	1338	607	19.2	33	75
ATU-52	9500	871	395	10.7	18.2	71	11200	1211	549	15.3	26	74	12500	1509	684	19.2	33	76

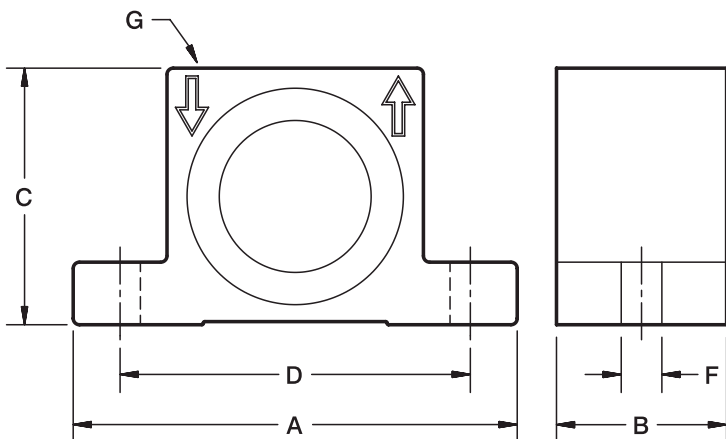

Model	Body Dimensions			Mounting		Port G (NPT)	Weight (kg)
	A	B	C	D	F		
ATU-21	89	34	51	67	6	1/8	0.3
ATU-22	89	34	51	67	6	1/8	0.3
ATU-23	89	34	51	67	6	1/8	0.3
ATU-31	113	43	65	89	9	1/4	0.6
ATU-32	113	43	65	89	9	1/4	0.6
ATU-33	113	43	65	89	9	1/4	0.6
ATU-41	146	57	80	102	9	1/4	1.2
ATU-42	146	57	80	102	9	1/4	1.2
ATU-43	146	57	80	102	9	1/4	1.3
ATU-51	178	74	100	127	12	3/8	2.3
ATU-52	178	74	100	127	12	3/8	2.5

Dimensions are in mm

Aerator Discharge Aids

What is an Aerator?

It is a Sintered Polythene cone shaped device that will assist the movement of powders, which normally flow, but need occasional assistance to get started or keep moving.

Aerators can be used to keep liquids and slurries live. They can also be used for nitrogen purging of vessels to evacuate oxygen.

Ideal for use with Cement, Lime, Powdered Milk, Phosphate Salt, Coal Dust, Pulverised Fly Ash, Alumina, Fullers Earth, Flour, Carbon Dust, Gypsum, Talc, Sawdust, Soap Powder and many more...

Aerators are unsuitable for oily, greasy, fatty materials or for powders which are hygroscopic.

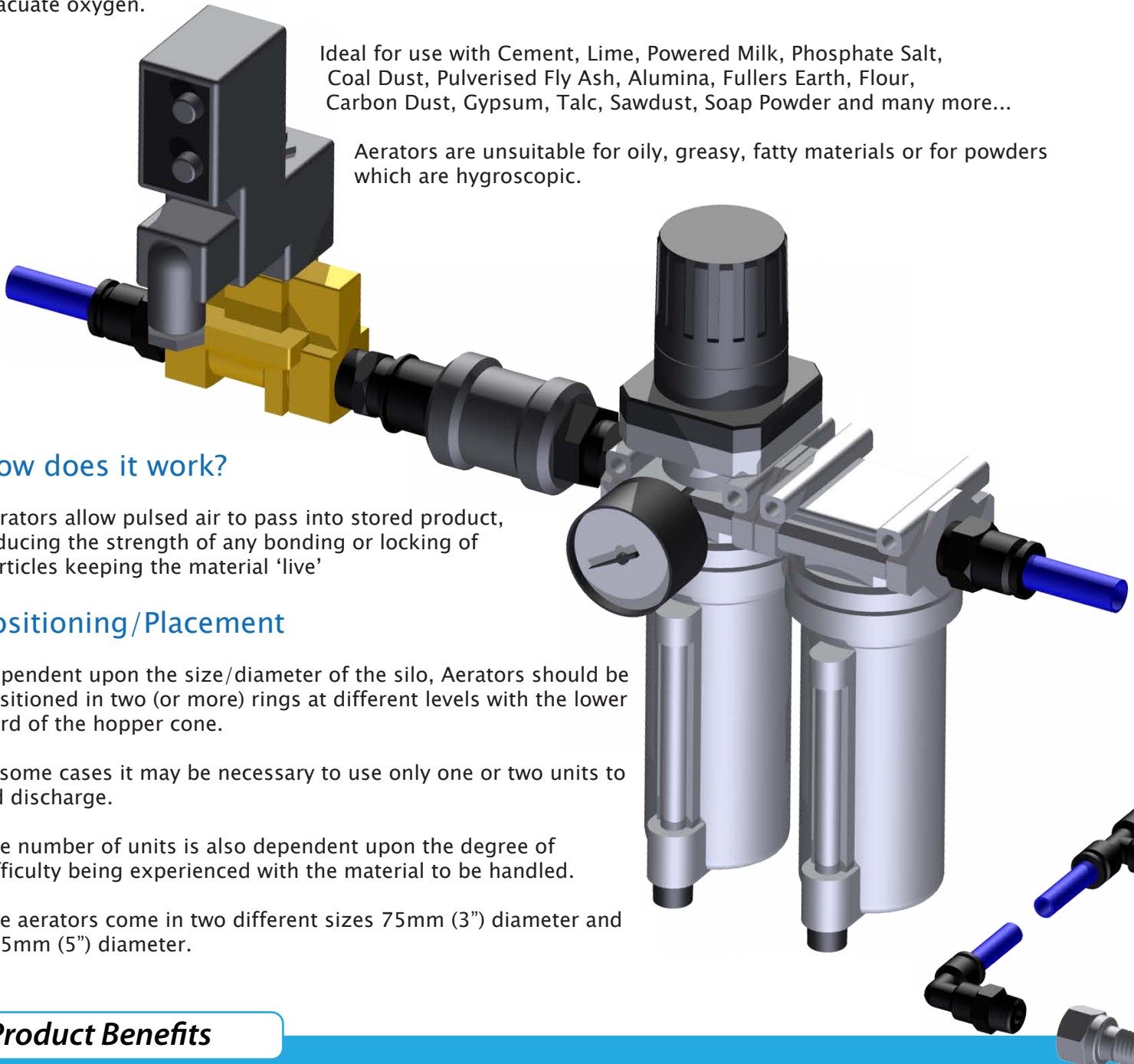

How does it work?

Aerators allow pulsed air to pass into stored product, reducing the strength of any bonding or locking of particles keeping the material 'live'

Positioning/Placement

Dependent upon the size/diameter of the silo, Aerators should be positioned in two (or more) rings at different levels with the lower third of the hopper cone.

In some cases it may be necessary to use only one or two units to aid discharge.

The number of units is also dependent upon the degree of difficulty being experienced with the material to be handled.

The aerators come in two different sizes 75mm (3") diameter and 125mm (5") diameter.

Product Benefits

- Easy to install
- Cost effective
- Flexible aerators conform to vessel radius
- Aerators provide a large zone of influence depending on product particle size
- Can be used in the food, pharmaceutical, chemical, mineral and cement industries
- Aerators are ideal for keeping dry powders and slurries alive
- Aerators are made from sintered FDA approved high density polyethylene aerator
- The Aerators are made with a stainless steel fixing/air connection with food grade natural rubber gasket

Aerator Discharge Aids

All materials of construction conform to US Food and Drug Administration (FDA) requirements for contact with foodstuffs.

Aerators can be sold as individual units to customers who wish to fit their own tubing etc. Alternatively, we can supply a standard package, which would include;

- Desired number of aerators
- 8mm dia. tubing, 20m long
- Push-in air line fittings
- Air regulator and gauge
- Pulse timer
- Air extractor/dryer equipment capable of removing moisture and particles to 0.01nm

Pulsed operation greatly reduces air consumption.

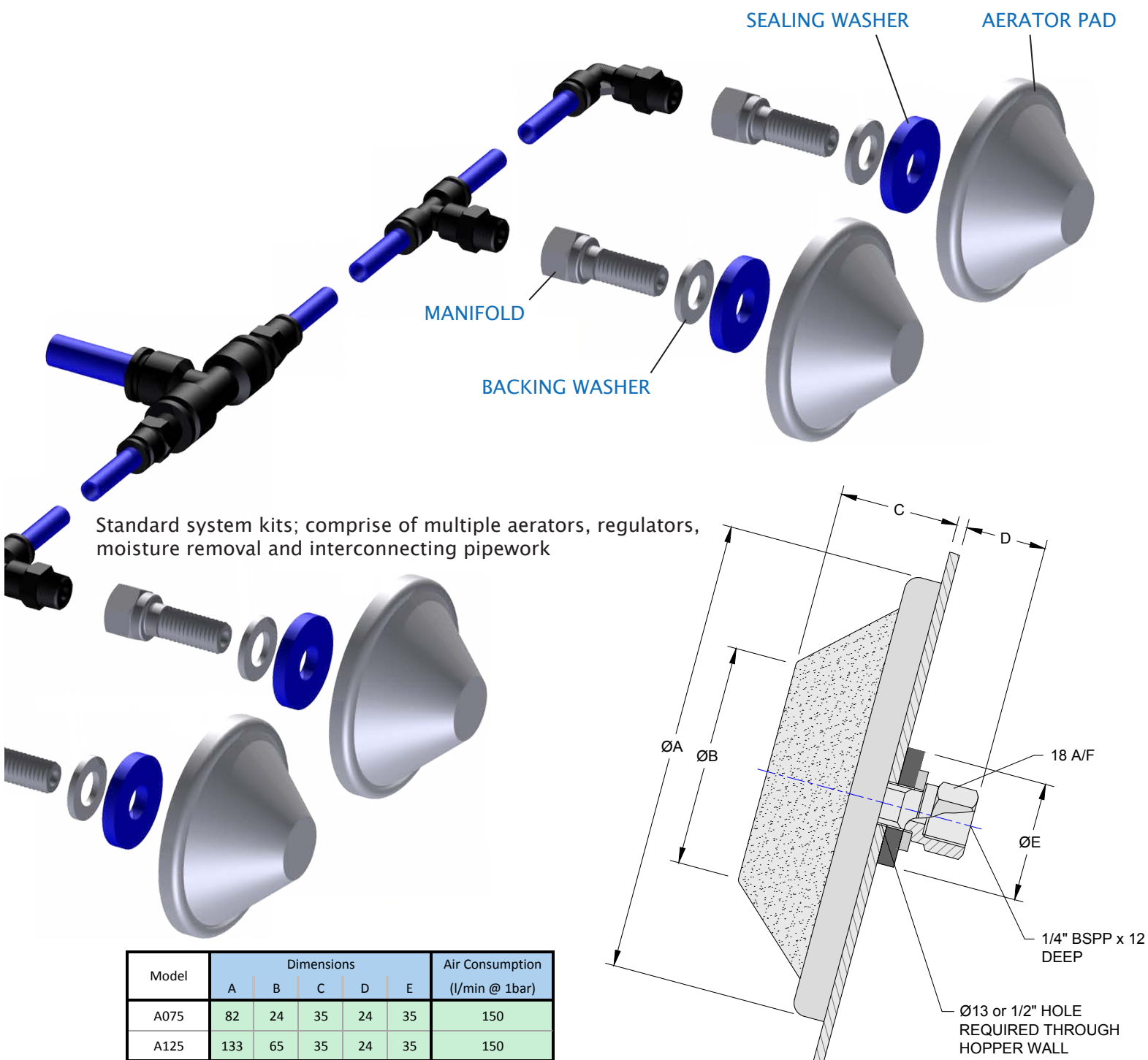

Standard system kits; comprise of multiple aerators, regulators, moisture removal and interconnecting pipework

Model	Dimensions					Air Consumption (l/min @ 1bar)
	A	B	C	D	E	
A075	82	24	35	24	35	150
A125	133	65	35	24	35	150

Dimensions are in mm

Aerator Discharge Aids

Technical Details

The following positioning / placement recommendations are based on worst case scenarios.

Silo diameters up to 1m

Use 8 x 75mm Aerators: 3 off in lower area of the cone and 5 off a third way up the cone.

Silo diameters between 1m and 2m

Use 3 x 75mm and 5 x 125mm Aerators: 3 off 75mm units in lower area of cone and 5 off 125mm units a third way up the cone.

Silo diameters over 2m

Use 8 x 125mm Aerators: 3 off in lower area of the cone and 5 off a third way up the cone.

On silos over 2m diameter the head height / load of product will also have an effect on the flow-ability and it may be necessary to use additional units at a higher level within the silo cone to prevent secondary bridging or rat holing.

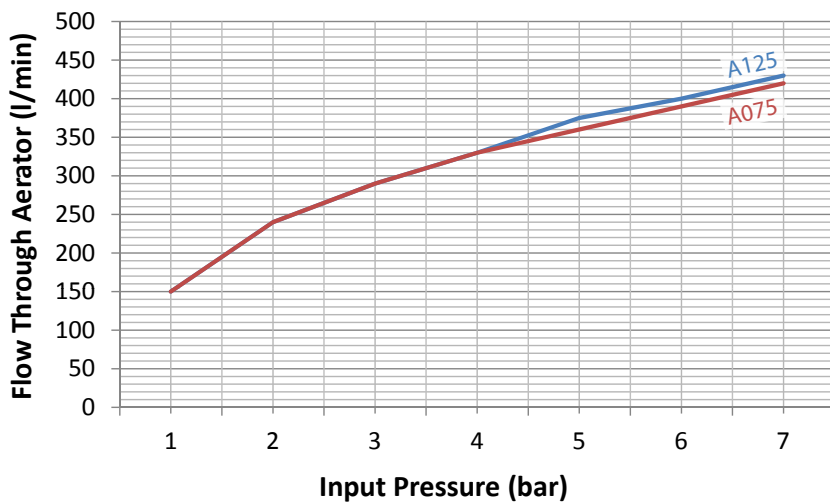
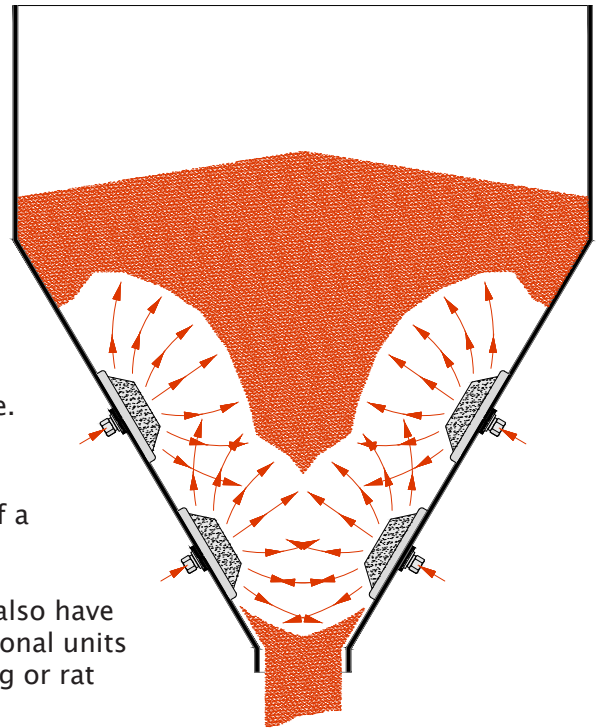

Air Requirements / Air Consumption

The supply should be filtered and dehumidified

Zones of Influence

Typical zones of influence are as follows:

- 75mm dia. Aerator = Approx 150mm to 175mm radius
- 125mm dia. Aerator = Approx 200mm to 250mm radius

Materials of construction

- Sintered Polyethylene cone 100 grade (20 to 60 micron)
- Polyethylene base with moulded in stainless steel nut
- Stainless Steel inlet manifold
- Food grade white rubber sealing washer
- Stainless Steel backing washer

Temperature Limitations

Minimum Temperature = -10°C
Maximum Temperature = 80°C

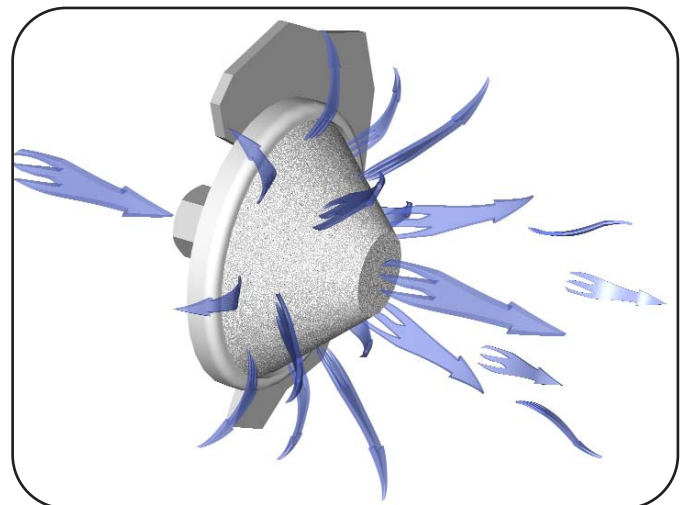

Discharge Aids Specification Data Sheet

Name: _____ Company: _____

Position: _____ Address: _____

Is there any type of discharge aid that you feel suits the application?

Promoflow Aerator Vibrator

Note: Please send drawing of storage bin. Describe existing bridging problems and methods currently used to restore flow

MATERIAL DATA

Material: _____ Range of Particle Sizes:

Bulk Density: _____ kg/m³ min Percent: _____ Size: _____

_____ kg/m³ max Percent: _____ Size: _____

Temperature: _____ °C Moisture: _____ %

PRESENT CONDITIONS

Frequent Stoppage <input type="checkbox"/>	Rat Holes <input type="checkbox"/>	Interlocks or Mats <input type="checkbox"/>
Occasional Stoppage <input type="checkbox"/>	Flushes <input type="checkbox"/>	Packs under pressure <input type="checkbox"/>
Bridges <input type="checkbox"/>	Hygroscopic <input type="checkbox"/>	Abrasive <input type="checkbox"/>
	Degradable <input type="checkbox"/>	

Corrosive to what materials? _____

Toxic Non-Toxic Special Handling Required? Specify _____

STORAGE BIN

Present Bin Construction: Carbon Steel Inside of Hopper to be: Painted
 Proposed Bin Stainless Steel Unpainted

Note: Indicate the approximate bridging area in your storage bin Wall thickness: _____

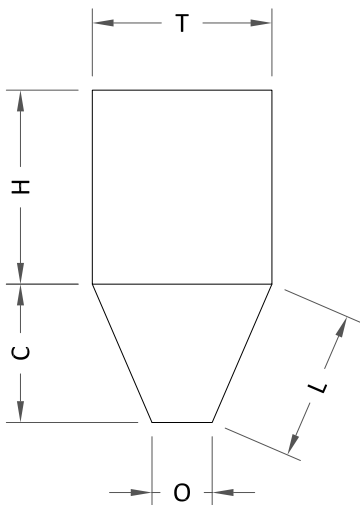

T _____ mm diameter
 or _____ mm square
 or _____ mm X _____ mm rectangular
 H _____ mm
 C _____ mm
 O _____ mm diameter
 or _____ mm square
 or _____ mm X _____ mm rectangular
 L _____ mm

OPERATION

Bin is filled to a capacity of: _____ kg or m³ (normal) _____ (max)

By: _____

Constantly Intermittently Average Rate: _____ Max Rate: _____

Bin is discharged into: _____

Constantly Intermittently Average Rate: _____ Max Rate: _____



Process Components Ltd
Graphic House
Bank Street
Macclesfield
Cheshire
SK11 7AR
United Kingdom

T: +44 (0) 1625 412000
F: +44 (0) 1625 412001

sales@mucon.com
www.mucon.com

Mucon is a registered trademark of Process Components Ltd