

Disc Valves

Disc Valves

Disc Valves

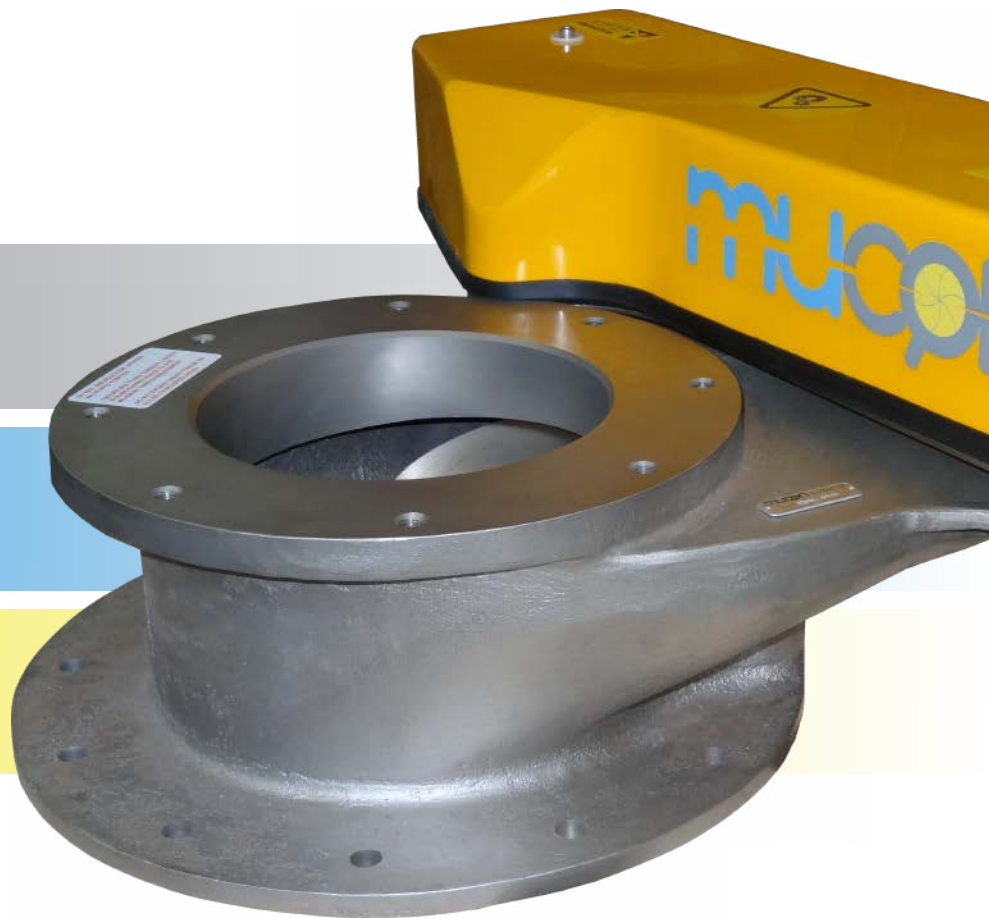

# Introduction

**Process Components Ltd** is the only manufacturer and supplier of the Mucon product range within the liquid, powder and bulk solids handling sectors.

## Products

- Iris Valves - The Original Mucon Valve
- Slide Gate Valves
- Butterfly Valves
- Disc Valves (Swing Gate Valves)
- Discharge Aids
- Level Indicators



## Industry Sectors

- Food Processing
- Pharmaceutical
- Chemical Processing
- Glass and Ceramics
- Plastics
- Sand and Cement

Mucon equipment has been used extensively in the bulk materials handling industries for over 60 years, during which time the company has built up an excellent reputation for both product reliability and service.

Industries search for increased economy, efficiency and demand for faster processing of bulk solids for an ever growing range of applications. This is where our specialist knowledge and proven expertise is unrivalled.

Whatever the powder or granule that requires handling, there will be a suitable Mucon product that will move it, measure it, control it and keep it moving quickly and efficiently.

Mucon Disc Valves (Swing Gate Valves) have been used around the world for the past 40 years. Their on going popularity is a testament to their ability to handle very problematic bulk solids without jamming. The valve is very robust and is often used with very abrasive products. In addition, it can handle pressures of 2.7 barg from beneath the valve. This product has proved to be the valve of choice where other valves have failed to meet end user requirements.

## The Origin

The Mucon brand has long been synonymous the world over for its well established range of Iris Diaphragm Valves. The Iris Valve in particular has long been recognised as the best valve for controlling the flow of bulk powders and solids. Over the years the Iris Valve has seen continued product development, resulting in a variety of models to suit a large array of customer applications.

However, despite the unique versatility of the Mucon Iris Diaphragm Valve, it is not suitable for every single application – particularly those involving high temperature, pressure or where regular inspection/maintenance is not possible.

The Mucon Disc Valve (Swing Gate Valve) was the result of a development exercise, where Mucon was challenged to produce a dry materials valve encompassing some of the advantages of Slide and Butterfly valves, but with none of their inherent disadvantages. The resultant design concept is simplicity itself; a factor which has been a major contribution to the Disc Valve's reputation for reliability and longevity.



The Disc valve in an open position

The Disc can be completely retracted into the recess, so that it does not obstruct the flow of material.

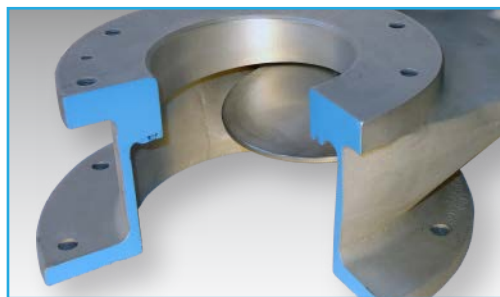

The half closed position

The Disc in this position does not make contact with the seals and remains free to 'float' a small amount on the radial support arm.

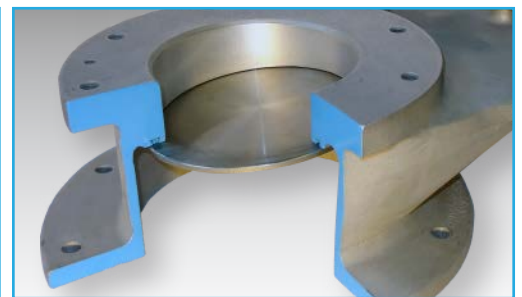

Fully closed

The Disc only makes contact with the seals over the last few degrees of hand lever movement and with a mild wedging action, provides a complete seal both through the valve and to the environment.

A free floating stainless steel disc, supported on a radially acting arm swings across the underside of the orifice through which product flows. Around the orifice is an angled seat face, therefore, as the disc closes onto the seal, it adopts the same angle, resulting in a mild wedging action; providing an excellent seal even to the finest powders. The customer has the option of choosing a manually or pneumatically actuated Disc Valve.

The disc slides over the angled seat by the minimum amount required to achieve a seal, reducing substantially any potential for mechanical wear. The absence of any guide ways and the use of a radial disc action ensures that material cannot jam the valve during operation.

The only component not part of the valve body casting is the shaft, which rotates the operating arm. This is easily sealed by 'O' rings or, for high temperature applications, by a stuffing box arrangement ensuring that no product can escape to atmosphere.

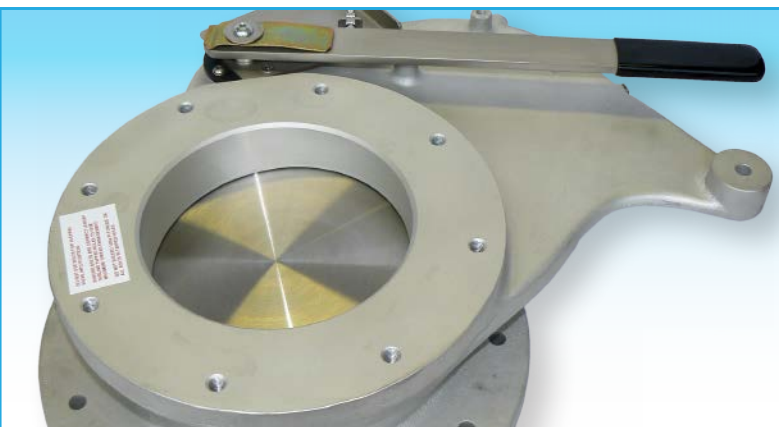

## **Main Features**

- Valve outlet is larger than the inlet ensuring full bore, uninterrupted flow of product, without transitional hang up
- Seating face is protected from direct abrasion
- Angled seating face ensures no jamming, as guide ways are not used for the slide plate to run on
- The disc is free floating on a radially moving arm. The disc as a result takes up the same angle as the seating face, thus creating a slight wedging action and dust tight seal, as well as compensating wear on the disc
- Disc is totally retracted from the area of product flow
- Standard Disc Valves are made from one-piece body casting
- Easy Maintenance 200mm and 100mm valves are made in two sections, allowing the valve internals to be removed whilst the valve is in-situ
- Easy Maintenance valves also have a replaceable seating face

A dovetail groove is machined into the seating face of the Disc Valve (Swing Gate Valve) to accept a specific 'O' ring best suited to the specific application. O-rings are required when there is a differential pressure across the valve. Their use is not essential for every application. For example, metal to metal sealing is used for those applications involving high temperatures.

The seat face is positioned out of the product flow and the outlet is at least 50mm larger than the inlet diameter. Both of these features ensure minimum wear to the valve, even when used with the most abrasive of products.

Our standard Disc Valves are produced from a single body casting, to meet the needs of customers wishing to use Disc Valves for applications requiring frequent thorough cleaning.

Most sizes also come in an 'Easy Maintenance' configuration that have operating internal parts, which can be removed and maintained in situ. In addition, the seat is renewable and does not necessarily have to be of the same material as the valve body.

All valves are furnished with blanked-off tappings to the Disc cavity. These have been introduced to accept air purging or to accommodate clean-in-place connections. This facility is especially useful when handling hygroscopic materials or where frequent cleaning of the valve is required.

## **Customer Benefits**

- Non-jamming action
- 100% product shut-off
- Full bore opening
- Dust tight to atmosphere
- Low maintenance
- High temperature applications
- Up to 2.7 Bar pressure BELOW disc
- Full vacuum ABOVE disc
- Able to close through a static column
- Able to seal against vapours, escaping to atmosphere
- Offers many years of reliable service
- Increased productivity
- Offers customers lower Total Cost of Ownership

Mucon Disc Valves (Swing Gate Valves) relish the most arduous of applications – be they abrasive products or high frequency operation. In such situations, they demonstrate their worth in terms of reliability, longevity and low maintenance. Not only will they consistently control the flow of product, they will ensure it stays within the system and does not leak to atmosphere.

Besides their proven worth as a general purpose, dry bulk solids shut-off valve, Disc Valves have demonstrated that they are the ideal valve for charging dry materials into reactor vessels. Many such vessels give off toxic and/or other hazardous vapours and operate under pressure and/or elevated temperatures.

When used in pairs, Disc Valves together with a safely vented spool piece, can form an effective airlock for loading substances into dangerous processes.

When used in conjunction with sequential operating controls, Disc Valves can be a viable alternative to Rotary Valves. One customer reported that they used a pair of Disc Valves to meter a mildly abrasive chemical. Each valve operated three times a minute, 24 hours per day for eighteen months before any attention was required. Previously the Rotary Valve, which the Disc Valves replaced, required daily attention to maintain a vacuum across the system.

Disc Valves could be used to control the flow of sand, cement and other additives from the bottom of silos. Some customers prefer the pneumatic Disc Valve to some manufacturers of pneumatic Slide Valves, as they avoid sealing problems/leakages and unlike some pneumatic Slide Valves, Disc Valves do not jam. As a result, operators experience less down time and increased productivity.

Disc Valves with a Flurene 177 coating can be used to control the flow of metallic powders in corrosive environments.

Pneumatic Disc Valves have been used by road tanker drivers for filling applications. The Disc Valve can be configured to be manually operated remotely by the driver.

Many customers use Disc Valves for loading and discharging materials such as chemicals from vacuum dryers etc.

Disc Valves (Swing Gate Valves) can often be found in the confectionery industry to handle milk powder, granulated sugar and cocoa powder. These are often fed into a ribbon mixer and blended under positive pressure. The Disc Valve on the outlet mixer is easily able to maintain pressure during the blending process and upon completion of the blending process the product can be discharged via a Disc Valve into a hopper.

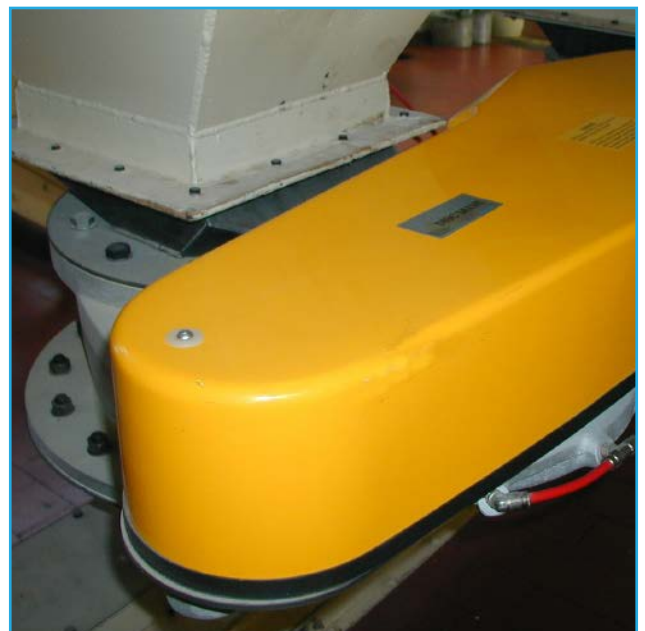

# Hand and Pneumatic Disc Valve Specifications

## Inlet Bore Sizes:

	Standard	Easy Maintenance
100mm (4in)		✓
150mm (6in)	✓	
200mm (8in)	✓	✓
250mm (10in)	✓	
300mm (12in)	✓	

## Body Materials:

- Standard
- Cast corrosion resistant LM25
  - Aluminium Alloy
  - Cast Iron grade SG200
  - Stainless Steel grade 316 (not available for 300mm valves)

## Body Finish:

- Standard
- Aluminium and Stainless Steel have a bead blast finish
  - Cast Iron epoxy painted externally, with a corrosion resistant coating internally
- Options
- Electroless Nickel Plating
  - Fluorocarbon coating

## Flanges:

- Standard
- BS 4504 NP 10 (hole positions only) equivalent to DIN 2532 (hole positions only)
- Options
- Alternatives to standard on application

## Disc Material:

- Standard
- Stainless Steel 316 S12 grade

## Radial Arm Material:

- Standard
- Cast Stainless Steel 347 S17 grade

## Operating Spindle:

- Standard
- Stainless Steel 316 S12 grade

## Bearings:

- Standard
- Cast Molybdenum filled Nylon
- Options
- Cast Iron grade 12 for high temperature applications

PTFE is used where temperature and corrosive considerations both apply

## Seat Seal:

- Standard
- Nitrile Rubber 'O' ring
- Options
- Silicone, Viton or PTFE encapsulated Viton Rubber 'O' ring

## Shaft Seals:

- Standard
- Nitrile Rubber 'O' rings
- Options
- Silicone or Viton Rubber 'O' rings
- Packed stuffing boxes would be used for high temperature applications

## Temperatures:

- Standard
- The standard Disc Valve can withstand temperatures of up to 100°C (212°F)
- Options
- When fitted with cast iron bearings and silicone seals, the Disc Valve is able to withstand temperatures of up to 200°C (392°F)
- Higher temperatures are possible for certain applications. In such circumstances a face seal is not required

## Pressure:

- Standard
- The standard Disc Valve specifications are suitable for differential pressures and vacuums of up to 0.35 barg (5 psig) across the seat face, provided that pressure relief is possible before the valve is operated, in applications where the pressure is on the underside of the disc
- Option
- Pressure tested valves are available upon special request up to a maximum operating pressure 2.7 barg (39 psig) dependent upon direction of effective differential pressure and nature of the product concerned

## Hand Valve

**Operation:** Hand Lever

**Operating Lever and Stop Plate:**

- Standard – Stainless Steel
- Easy Clean – Cast Aluminium/Plastic

**Weights:**

Size	Aluminium	Cast Iron	Stainless Steel
100mm (4in)	10.5kg (23lbs)	24.5kg (54lbs)	30kg (66lbs)
150mm (6in)	15kg (33lbs)	35kg (77lbs)	42kg (92lbs)
200mm (8in)	20kg (44lbs)	45kg (99lbs)	54kg (119lbs)
250mm (10in)	55kg (121lbs)	90kg (198lbs)	110kg (242lbs)
300mm (12in)	75kg (165lbs)	145kg (319lbs)	

**Air Purge Facility:**

- Standard – Plugged air purge point connection into Disc recess area

## Pneumatic Valve

**Operation:** Pneumatic cylinder mounted on a stainless steel plate and covered by a glass reinforced plastic cover

**Supply and Consumption:**

**Air Supply** 5.5 barg (80 psig) Clean lubricated or non-lubricated compressed air

**Consumption:\***

Size	cm <sup>3</sup> /stroke
100mm (4in)	20
150mm (6in)	60
200mm (8in)	100
250mm (10in)	420
300mm (12in)	460

\* The figures are provided for continuous operation of the valve.

**Electric Supply:**

110v or 240v, 1ph, 50Hz or 60Hz depending on voltage of solenoid valve fitted

**Weights:**

Size	Aluminium	Cast Iron	Stainless Steel
100mm (4in)	18kg (39lbs)	32kg (69lbs)	38kg (84lbs)
150mm (6in)	25kg (55lbs)	45kg (99lbs)	54kg (119lbs)
200mm (8in)	30kg (66lbs)	55kg (121lbs)	66kg (145lbs)
250mm (10in)	60kg (132lbs)	100kg (220lbs)	120kg (265lbs)
300mm (12in)	90kg (198lbs)	160kg (352lbs)	

**Optional Extras:**

Operating Solenoids – Failsafe Assembly, Limit Switches – Full Trickle Feed facility

# Standard Hand Operated

Nom Bore	J-HOLES										K-HOLES				L-HOLES				M-HOLES				
	ØA	ØB	ØC	D	E	ØF	H	G Rad	I	QTY	THD	PCD	DEPTH	QTY	THD	PCD	DEPTH	QTY	THD	PCD	P°	DEPTH	Q°
150	200	280	140	161	336	253	445	295	4	M12	240	THRO	4	M12	240	24	24	6	M12	295	24	6.5	6.5
200	250	335	160	183	400	239	445	330	4	M12	295	THRO	4	M12	295	20	20	9	M12	350	20	10.5	18
250	300	410	200	245	480	310	575	445	4	M16	350	THRO	8	M16	350	20	20	8	M16	400	12	25	12
300	400	480	235	282	595	367	620	515	12	M16	400	30	N/A	N/A	N/A	N/A	N/A	11	M16	515	30	18	10.5

Unless otherwise stated, all dimensions in mm

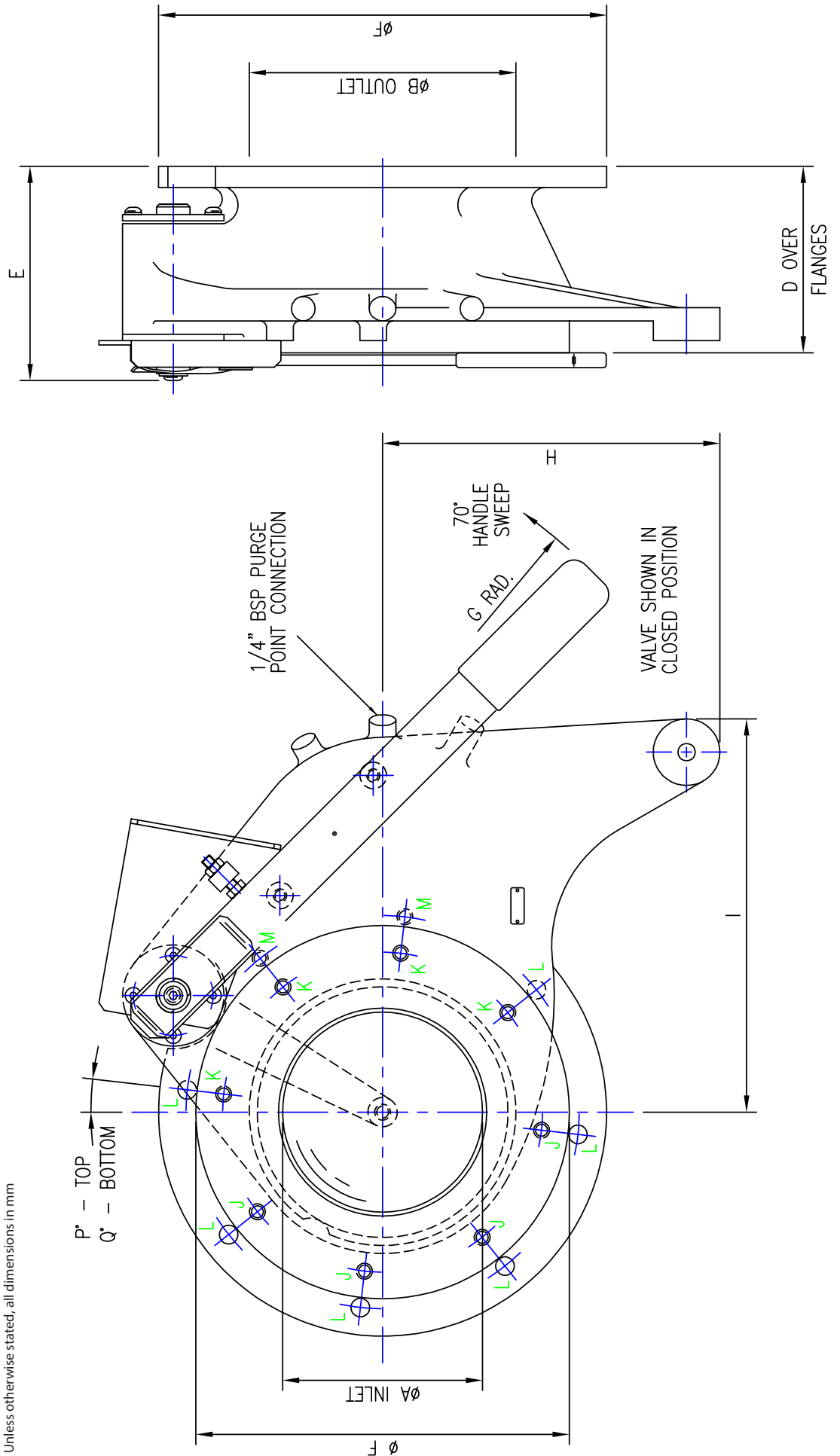



Valve Type	Nom Bore	A	B	C	D	E	F	G	H	J	K	L	M	N	P	R	S	T	U	W	X	Y	Z	A1	B1	C1	D1
DV6	150	150	200	280	336	24	16	130	140	250	95	50	335	260	632	6.5°	6.5°	4	M12	4	M12	20	240	6	14	2	M12
DV8	200	200	250	335	400	23	19	153	160	280	105	73	395	260	680	10.5°	18°	4	M12	4	M12	20	295	9	14	3	M12
DV10	250	250	300	410	480	25	25	193	200	335	125	78	505	325	795	12°	12°	4	M16	8	M16	20	350	8	18	4	M16
DV12	300	300	400	480	595	29	23	234	235	405	150	100	590	401	1005	18°	10.5°	N/A	N/A	12	M16	30	400	11	18	4	M16

Unless otherwise stated, all dimensions in mm / Weights given in kgs

Valve Type	E1	F1	ALI	CI	Nett Weight
DV6	20	295	25	45	54
DV8	20	350	30	55	66
DV10	25	400	60	100	120
DV12	30	515	90	160	N/A

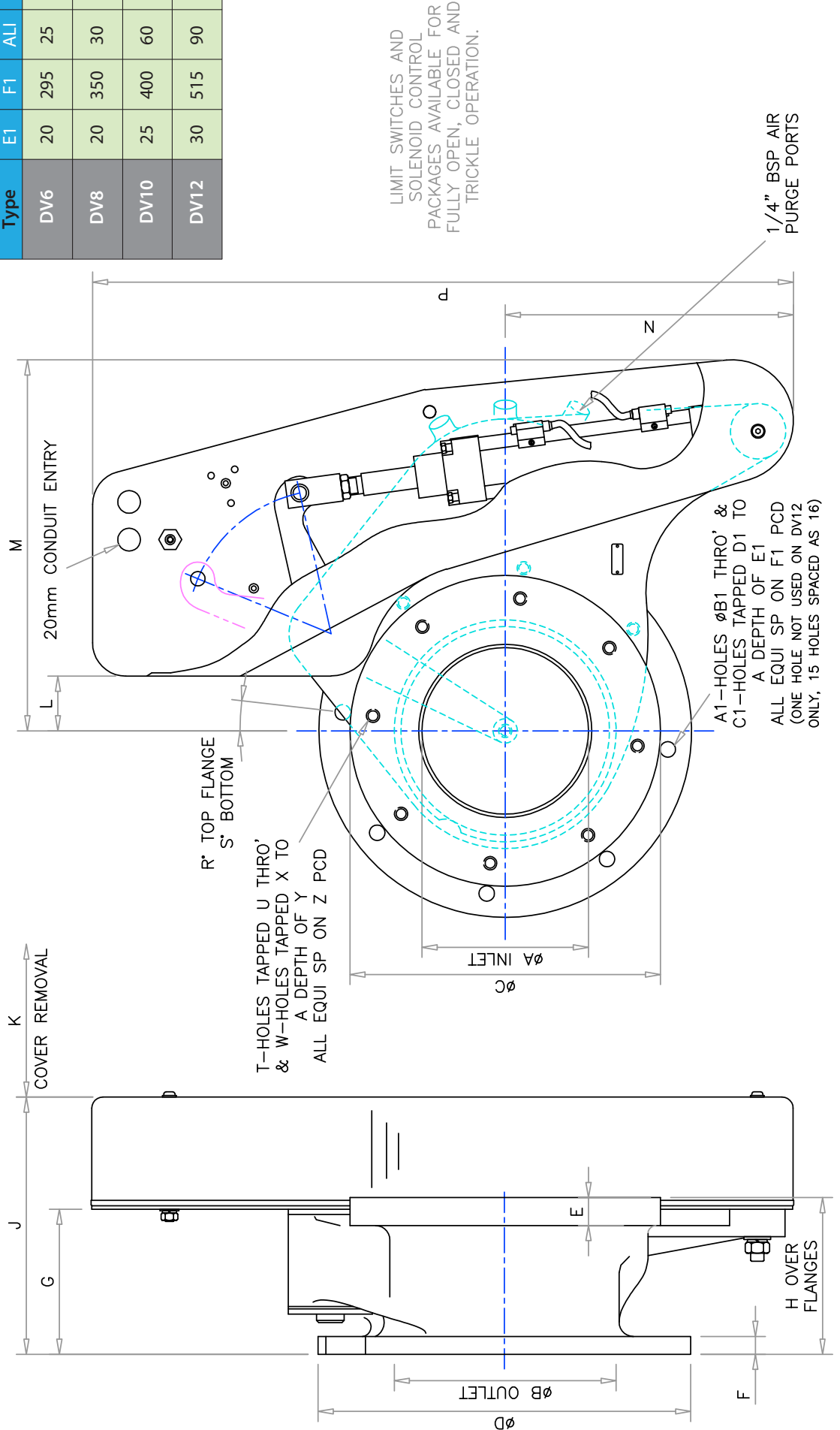

# Easy Maintenance Hand Operated

Valve Type	Nom Bore	A	B	C	D	E	F	G	H	J	K	L	R	S	T	U	W	X	Y	Z	A1	B1	C1	D1	E1	F1
DV4	100	110	150	228	280	18	18	130	106	235	135	255	0°	0°	0	-	8	M10	15	170	4	M10	4	M10	15	225
DV8	200	200	250	335	400	23	18	145	172	365	175	255	22.5°	20°	4	14	4	M12	15	295	6	14	6	M12	17	350

Unless otherwise stated, all dimensions in mm

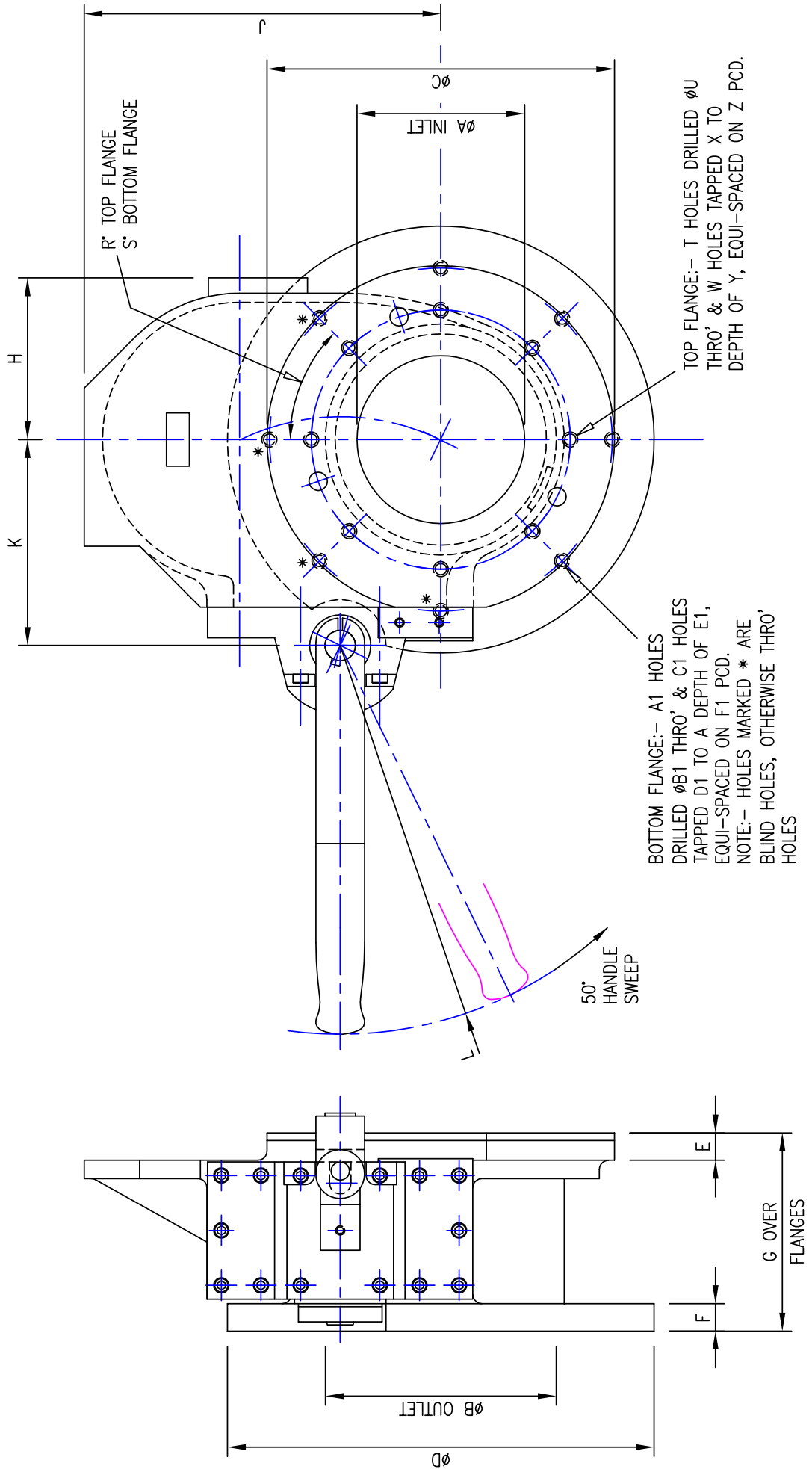

Valve Type	Nom Bore
DV4	100
DV8	200

A	B	C	D	E	F	G	H	J	K	L	M	N	P	R	S	T	U	W	X	Y	Z
110	150	228	280	18	18	152	130	40	150	200	106	490	402	0	0	0	-	8	M10	15	170
200	250	335	400	23	18	190	145	40	150	277	172	744	532	22.5	20	4	14	4	M12	15	295

Unless otherwise stated, all dimensions in mm / Weights given in kgs

Valve Type	Valve Type										Nett Weight	
	A1	B1	C1	D1	E1	F1	ALI	CI	316	316		
DV4	4	M10	4	M10	15	225	17.5	31.5	38	38		
DV8	6	14	6	M12	17	350	30	55	66	66		

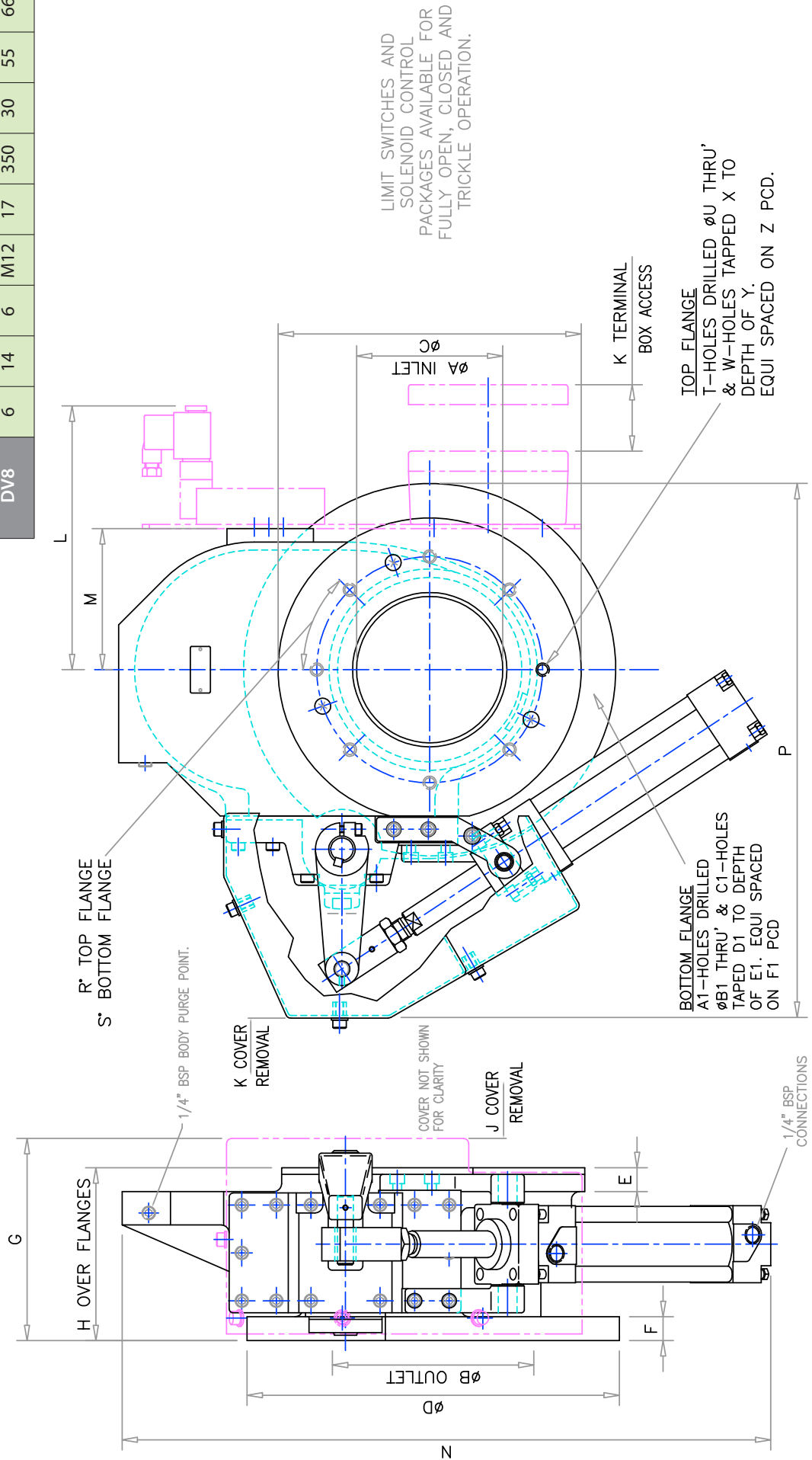



Process Components Ltd  
Graphic House  
Bank Street  
Macclesfield  
Cheshire  
SK11 7AR  
United Kingdom

T: +44 (0) 1625 412000  
F: +44 (0) 1625 412001

[sales@mucon.com](mailto:sales@mucon.com)  
[www.mucon.com](http://www.mucon.com)

Mucon is a registered trademark of Process Components Ltd